



**REMOTE WATER PUMP
INSTALLATION APPENDIX**
for model 7165, 8165
MasterFlush® toilets

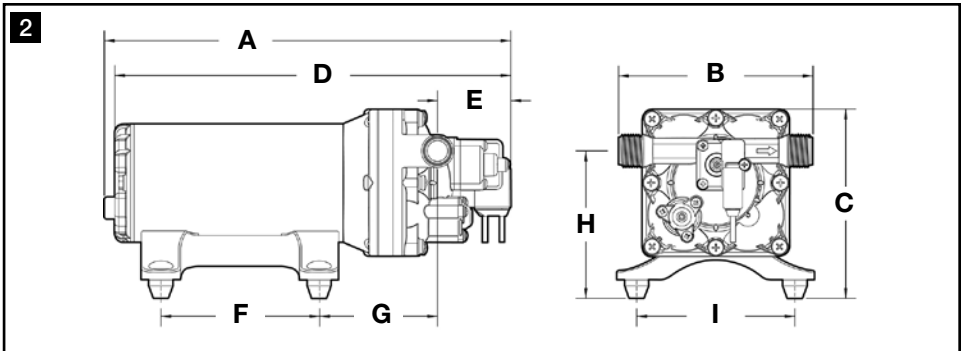

Table of contents

EN

1	Notes on using the manual	3
2	General safety instructions	3 - 4
3	Intended use	4
4	Specifications	5
5	Components	5
6	Installation	6 - 8
7	Operation	9
8	Cleaning/winterizing	9
9	Troubleshooting	10
10	Warranty	10 - 11

1 Notes on using the manual



Caution!

Safety Instruction: Failure to observe this instruction can cause material damage and impair the function of the device.



Note

Supplementary information for operating the device.

fig. 1 A, page 2 : This refers to an element in an illustration. In this example, item A in figure 1 on page 2.

2 General safety instructions

The manufacturer will not be held liable for claims for damage resulting from the following:

- Faulty assembly or connection
- Damage to the unit from mechanical influences, misuse or abuse
- Alterations to the unit without express written permission from the manufacturer
- Use for purposes other than those described in the operating manual

2.1 Warnings – marine applications

The following statements must be read and understood before installing, servicing and/or operating this product on a boat. Modification of this product may result in property damage.

Dometic recommends that a qualified marine technician or electrician install or service this product. Equipment damage, injury to personnel or death could result from improper installation. DOMETIC ACCEPTS NO RESPONSIBILITY OR LIABILITY FOR DAMAGE TO EQUIPMENT, OR INJURY OR DEATH TO PERSONNEL THAT MAY RESULT FROM IMPROPER INSTALLATION, SERVICE OR OPERATION OF THIS PRODUCT.



Caution! Hazard of Flooding

If the toilet is connected to ANY through-the-hull fittings, properly installed seacocks MUST be installed in all piping connected to through-the-hull fittings. Seacocks MUST be easily accessible to all users of the toilet or secondary valves fitted in hoses where they are easily accessible. All valves MUST be full bore valves and of marine quality. Screw-to-close gate valves are not recommended. Failure to do so can result in flooding which can cause loss of property and life.



Caution! Hazard of Flooding

If toilet is connected to ANY through-the-hull fittings, ALL flexible hoses must be of marine sanitation quality and must be secured to ANY fittings (such as those at seacock, vented loop or toilet) with two stainless steel, worm-drive hose band clamps at each connection. Connections MUST be checked frequently for integrity. Failure to comply can result in flooding which can cause loss of property and life.



Caution! Hazard of Flooding

If toilet rim is ever less than 8 in. (20 cm) above the highest possible waterline at ANY time (during any conditions of heel, load or trim) and is connected to ANY through-the-hull fittings, properly positioned ventilated (vented) loops MUST be installed in intake or discharge piping to prevent potential back siphonage of seawater into the boat. Vented loops must be equipped with integral check valve that permits air into line to prevent siphoning. Failure to do so can result in flooding which can cause loss of property and life.

**Caution! Hazard of Flooding**

Do not connect raw water flush toilet to an onboard pressurized water system. Failure to comply can result in flooding which can cause loss of property and life.

**Caution!**

Do not connect raw water flush toilet to an onboard potable water system. Failure to comply could result in contamination of the potable water supply.

**Caution! Hazard of Flooding**

Before beginning any work on this product, be sure that all electrical power to the unit has been turned off and that seacocks are in the CLOSED or OFF position. Failure to do so can result in flooding which can cause loss of property and life.

**Caution! Hazard of Shock or Fire**

Always use recommended fuse, circuit breaker and wire size. Failure to do so can result in fire that can cause the loss of property and life.

**Caution!**

Overfilling the holding tank can create serious damage to the sanitation system, such as rupturing the holding tank and releasing tank contents into the bilge. To prevent this possibility, Dometic recommends using a “full” tank shut-down relay from the “full” signal generated by an optional Dometic DTM01C tank monitor or DTM04 four-level tank monitor system.

**Caution!**

Discharge of sewage directly overboard is illegal in some areas. Please check all local laws before operating an overboard discharge sanitation system.

3 Intended use

The Dometic Remote Water Pump provides quiet, reliable and thermally protected performance in a demand-based toilet water supply system. The integrated strainer filters raw water or sea water to protect the toilet from small particles that may be suspended in raw water.

3.1 Benefits

Quiet toilet operation. Remote water pump installs in raw water supply line outside of head compartment for much quieter toilet operation.

Dependable performance. Designed for intermittent high flow demand, smooth operation and no rapid cycling.

Marine-ready design. Self-priming up to 6 ft./1.83 m and dry-run capable, it features a sealed switch, sealed and thermally protected motor, corrosion-resistant electro-coated motor and ignition protection (CE).

4 Specifications

4.1 Minimum system requirements

Electrical	Amp draw (average)	20 amps at 12 V DC*
	Fuse/breaker	25 amps*
Water supply	Pump location	within 6 ft./1.8 m of water source
	Pump inlet/outlet	3/4 in. ID flexible high-pressure hose
	Toilet inlet	3/4 in. ID flexible high-pressure hose
Discharge	Toilet**	1 in./25 mm or 1.5 in./38mm sanitation hose

* Macerator toilet and remote water pump are combined on one circuit.

** Model 7165 and 8165 toilets include fittings for two discharge hose size options.

Specifications subject to change without notice.



CAUTION! ELECTRICAL HAZARD

DO NOT CONNECT DOMETIC REMOTE WATER PUMP DIRECTLY TO STANDARD RESIDENTIAL WIRING SYSTEM. This water pump operates on 12 V DC.

4.2 Dimensions (fig. 2 , page 2)

Ref.	Dimension
A	10.28 in. / 261 mm
B	4.92 in. / 125 mm
C	4.78 in. / 121 mm
D	10.02 in. / 255 mm

Ref.	Dimension
E	1.86 in. / 47 mm
F	4 in. / 102 mm
G	3 in. / 76 mm
H	3.72 in. / 95 mm
I	4 in. / 102 mm

5 Components

(fig. 1 , page 2)

Ref.	Description
A	Remote water pump
B	Water inlet strainer

Ref.	Description
C	0.75 in. ID elbow hose fittings (2)
D	0.75 in. ID straight hose fittings (2)

6 Installation



Note

Determine whether the toilet will be above or below the vessel's water line, and if it will discharge overboard or to a holding tank, and then follow the appropriate diagram for the installation.

6.1 Above water line system layouts

3 Toilet with direct overboard discharge

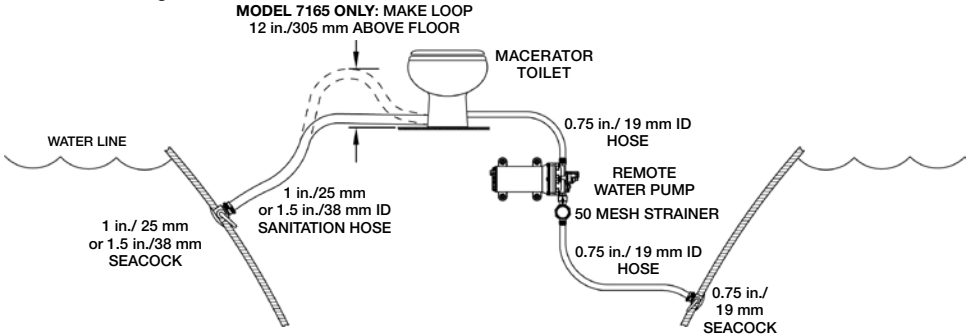

IMPORTANT INSTALLATION NOTES – ABOVE WATER LINE SYSTEMS:

1. Bowl rim must be a MINIMUM of 8 in./20 cm above the highest possible water line at full heel.
2. All vented loops must be a MINIMUM of 8 in./20 cm above the highest possible water line at full heel.
3. Maximum raw water pump suction lift: 6 ft./183 cm.
4. Maximum discharge head: model 7165 toilet - 4 ft./120 cm; model 8165 toilet - 10 ft./305 cm.

4 Toilet with holding tank discharge

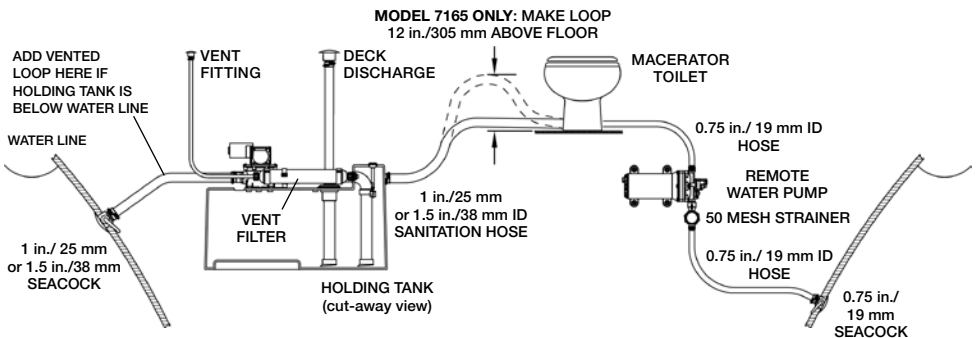

Note

REFER TO SEPARATE WIRING DIAGRAMS FOR REQUIRED ELECTRICAL CONNECTIONS.



Caution! Hazard of Flooding

All vented loops should be installed a minimum of 8 in./20 cm above water line at full heel.

6.2 Below water line system layouts

5 Toilet with direct overboard discharge

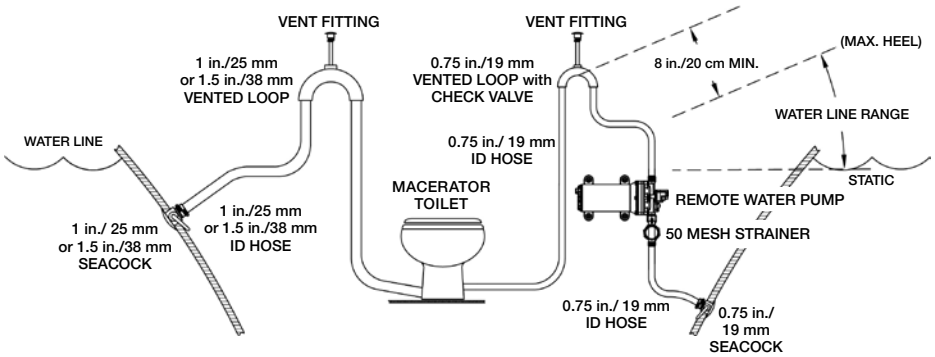

IMPORTANT INSTALLATION NOTES – BELOW WATER LINE SYSTEMS:

1. Vented loops must use either a duckbill valve or an electrically operated normally-open solenoid valve.
2. All vented loops must be a MINIMUM of 8 in./20 cm above the highest possible water line at full heel.
3. Vented loops are recommended to be installed as close to minimum height of 8 in./20 cm for optimum water flow and toilet flushing performance.
4. All vented loops must be a MAXIMUM of 24 in./50 cm above water line (see Note 3).
5. Installation of vented loops can be optimized by locating them near center of boat where height fluctuation during heeling is minimal.
6. Maximum raw water pump suction lift: 6 ft./183 cm.
7. Maximum discharge head: model 7165 toilet - 4 ft./120 cm; model 8165 toilet - 10 ft./305 cm.

6 Toilet with holding tank discharge

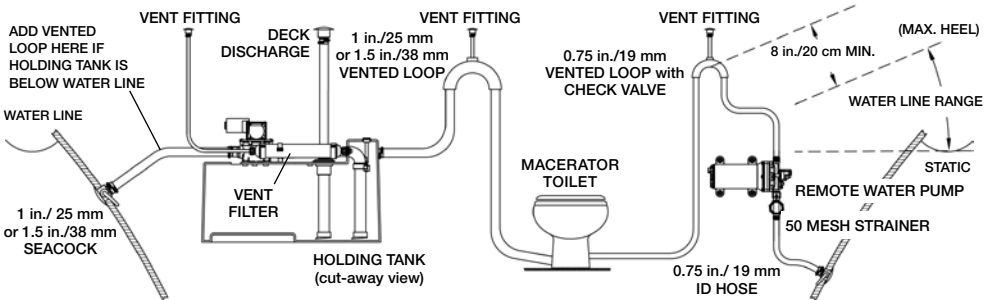

Note

REFER TO SEPARATE WIRING DIAGRAMS FOR REQUIRED ELECTRICAL CONNECTIONS.



Caution! Hazard of Flooding

All vented loops should be installed a minimum of 8 in./20 cm above water line at full heel.

6.3 System installation guidelines

Remote water pump location:

1. Install pump on a solid surface in an accessible location for strainer cleaning and pump maintenance.
2. Place pump within 6 ft./1.8 m (maximum) of raw water source.
3. Pump should be installed in a 1 cu. ft./0.03 cu. m minimum space for adequate ventilation.
4. Pump may be installed in any position.
5. Pump is designed for intermittent duty only. Do not use water pump for continuous reverse osmosis (RO) water filtration system or similar continuous function.

Water inlet strainer:

1. Attach the water inlet strainer (**1** B, p. 2) to the supply side of the pump with the threaded adapter. Securely finger-tighten the connection. Make sure flow direction arrow on strainer is in same direction as the arrow on the pump.

Plumbing:

1. Use 0.75 in./19 mm ID flexible high-pressure water hose for inlet and outlet water connections. DO NOT use plastic or rigid pipe or the pump's normal motion will transmit through the rigid plumbing and cause noise or possible loosening/ damaging of components.
2. Make sure all water hose connections and runs have no sharp bends or restrictions.
3. Reduce restrictions in water line, including smaller inside diameter shut-off valves, winterizing valves and elbows.
4. Connect water hose to MasterFlush toilet at fitting in back of toilet (**7**) with two hose clamps.



Electrical supply:

1. Recommended 25-amp fuse or breaker powers both electric toilet and remote water pump.
2. For marine applications, follow ABYC wiring standards for gauge and length specifications.
3. Refer to wiring diagram on reverse side of toilet parts list for specific toilet system
4. Follow other appropriate installation instructions from chapter 5 of MasterFlush toilet manual (provided with toilet).

MasterFlush toilet:

1. For toilet and flush switch installation, refer to installation manual for the MasterFlush toilet (packed separately).



Warning!

Do not connect seawater-flush toilet inlet line to a pressurized freshwater system.

This will result in a continuously running freshwater pump, which can possibly overflow the toilet bowl, flood the boat, and cause potential loss of property or life.



Warning!

Do not connect seawater-flush toilet inlet line to an onboard potable water system in any way. This can cause contamination of the potable water system.

7 Operation

The Dometic Remote Water Pump (DRWP) is designed for intermittent use only. It operates normally up to about 30 PSI (2.06 Bar), providing a smooth, steady flow with minimal cycling. When the flush switch is activated for flushing or adding water to the toilet bowl, the water pump delivers water to the toilet bowl while the switch is pressed.



Note

Shut off power to remote water pump when leaving the boat unattended.

8 Cleaning/winterizing

8.1 Water inlet strainer

Periodically clean water inlet strainer of any debris which may have accumulated, especially if water flow to toilet has become noticeably slower. Unscrew the clear reservoir from the strainer body, rinse out the debris and screw the reservoir securely onto the body.

8.2 Toilet/water pump system

1. **IMPORTANT!** Close seacock at water inlet.
2. Disconnect water line from inlet seacock.
3. Turn on power to pump by pressing flush switch. Keep flushing until water is expelled through toilet.
4. Fill a 2-gallon/7.6-liter container with a chlorine bleach/water mixture ratio of 1/8 fl. oz.:1 gallon or 1 ml:1 liter.
5. Submerge disconnected end of inlet hose into mixture, then press and hold flush switch to pump mixture into toilet all the way to top of bowl rim. Make sure pump does not start pumping air.
6. Allow four hours for mixture to disinfect system. **NOTE:** Doubling the bleach concentration will reduce the contact time to one hour.
7. **IMPORTANT!** Reconnect inlet water line to seacock, making sure connections are secure. Open seacock to continue normal toilet use.

8.3 Winterizing

1. **IMPORTANT!** Close seacock at water inlet.
2. Disconnect water line from inlet seacock.
3. Turn on power to pump by pressing flush switch. Keep flushing until water is expelled through toilet.
4. Fill a container with potable water system antifreeze and submerge open end of inlet water hose into container.
5. Press and hold flush switch to pump antifreeze mixture into toilet all the way to top of bowl rim. Make sure pump does not start pumping air.
6. **IMPORTANT!** Reconnect inlet water line to seacock, making sure connections are secure.
7. Turn off electrical power to pump.

9 Troubleshooting

Problem	Possible Cause	Service Instruction
1. Pump will not start/blows circuit.	a. Interrupted electrical power to pump. b. Overheated motor. c. Seized or locked diaphragm assembly due to freezing.	a. Check electrical connections, fuse or breaker, main switch and ground. b. Thermal breaker may have triggered. It will reset when cool. c. Thaw out pump. Prevent from freezing (see "Winterizing").
2. Pump sputters or will not prime (motor runs but no discharge).	a. Clogged inlet strainer. b. No or low water flow to inlet. b. Clogged inlet or outlet port.	a. Clean out inlet strainer. b. Make sure inlet seacock is open and there are no sharp bends or restrictions in water hose. b. Check pump's threaded inlet and outlet ports for debris.
3. Pump will not shut off – water keeps flowing into toilet.	a. Pump is wired incorrectly. b. Toilet flush switch is malfunctioning.	a. Use wiring diagram on reverse side of toilet parts list. b. Replace flush switch.
4. Noisy or rough pump operation.	a. Air has entered water supply system. b. Loose plumbing or mounting connections.	a. Check plumbing connections for leaks. Tighten if necessary. b. Check plumbing connections and mounting bolts to assure tight connections.

10 Warranty

The statutory warranty period applies. If the product is defective, please contact your retailer or the manufacturer's branch in your country (see the back of the instruction manual for the addresses).

For repair and guarantee processing, please include the following documents when you send in the device:

- a copy of the receipt with purchasing date
- a reason for the claim or description of the fault

Europe:

Warranty and Customer Service

Warranty arrangements are in accordance with EC Directive 44/1999/CE and the normal conditions applicable for the country concerned. For warranty or other service, please contact our Dometic/Waeco Service department listed elsewhere in this manual. Any damage due to improper use is not covered by the warranty.

The warranty does not cover any modifications to the product or the use of non-original Dometic parts; the warranty does not apply if the installation and operating instructions are not adhered to and no liability shall be entertained.

(continued on next page)

Product Liability

Product liability of Dometic Group and its subsidiary companies does not include damages which may arise from: faulty operation; improper alterations or intervention in the equipment; adverse effects from the environment which may impact the equipment itself or the direct vicinity of the equipment or persons in the area.

To obtain warranty service, first contact your local dealer from whom you purchased this product or go to dometic.com for a dealer near you.

North America and Rest of the World:**Manufacturer's One-Year Limited Warranty**

Dometic Corporation, Sanitation Division warrants to the original purchaser only that this product, if used for personal, family or household purposes, is free from defects in material and workmanship for a period of one year from the date of purchase.

If this Dometic product is placed in commercial or business use, it will be warranted to the original purchaser only to be free of defects in material and workmanship for a period of ninety (90) days from the date of purchase.

Dometic reserves the right to replace or repair any part of this product that proves, upon inspection by Dometic, to be defective in material or workmanship. All labor and transportation costs or charges incidental to warranty service are to be borne by the purchaser-user.

EXCLUSIONS

IN NO EVENT SHALL DOMETIC BE LIABLE FOR INCIDENTAL OR CONSEQUENTIAL DAMAGES, FOR DAMAGES RESULTING FROM IMPROPER INSTALLATION, OR FOR DAMAGES CAUSED BY NEGLIGENCE, ABUSE, ALTERATION OR USE OF UNAUTHORIZED COMPONENTS. ALL IMPLIED WARRANTIES, INCLUDING ANY IMPLIED WARRANTY OF MERCHANTABILITY OR FITNESS FOR ANY PARTICULAR PURPOSE, ARE LIMITED TO A PERIOD OF ONE YEAR FROM DATE OF PURCHASE.

IMPLIED WARRANTIES

No person is authorized to change, add to, or create any warranty or obligation other than that set forth herein. Implied warranties, including those of merchantability and fitness for a particular purpose, are limited to one (1) year from the date of purchase for products used for personal, family or household purposes, and ninety (90) days from the date of purchase for products placed in commercial or business use.

OTHER RIGHTS

Some states do not allow limitations on the duration of an implied warranty and some states do not allow exclusions or limitations regarding incidental or consequential damages; so, the above limitations may not apply to you. This warranty gives you specific legal rights, and you may have other rights which vary from state to state.

To obtain warranty service, first contact your local dealer from whom you purchased this product or go to dometic.com for a dealer near you.

GERMANY

Dometic WAECO International GmbH
Hollefeldstraße 63 · D-48282 Emsdetten
☎ +49 (0) 2572 879-195 · 📠 +49 (0) 2572 879-322
Mail: info@dometic-waeco.de · Internet: www.dometic-waeco.de

AUSTRALIA

Dometic Australia Pty. Ltd.
1 John Duncan Court
Varsity Lakes QLD 4227
☎ 1800 212121
📠 +61 7 55076001
Mail: sales@dometic-waeco.com.au

AUSTRIA

Dometic Austria GmbH
Neudorferstraße 108
A-2353 Guntramsdorf
☎ +43 2236 908070
📠 +43 2236 90807060
Mail: info@dometic.at

BENELUX

Dometic Branch Office Belgium
Zincstraat 3
B-1500 Halle
☎ +32 2 3598040
📠 +32 2 3598050
Mail: info@dometic.be

BRAZIL

Dometic DO Brasil LTDA
Avenida Paulista 1754, conj. 111
SP 01310-920 Sao Paulo
☎ +55 11 3251 3352
📠 +55 11 3251 3362
Mail: info@dometic.com.br

DENMARK

Dometic Denmark A/S
Nordensvej 15, Taulov
DK-7000 Fredericia
☎ +45 75585966
📠 +45 75586307
Mail: info@dometic.dk

FINLAND

Dometic Finland OY
Mestarinie 4
FIN-01730 Vantaa
☎ +358 20 7413220
📠 +358 9 7593700
Mail: info@dometic.fi

FRANCE

Dometic SAS
ZA du Pré de la Dame Jeanne
B.P. 5
F-60128 Plailly
☎ +33 3 44633525
📠 +33 3 44633518
Mail : vehiculesdeloisirs@dometic.fr

HONG KONG

Dometic Group Asia Pacific
Suites 2207-11 22/F - Tower 1
The Gateway - 25 Canton Road,
Tsim Sha Tsui - Kowloon
☎ +852 2 4611386
📠 +852 2 4865563
Mail: info@waeco.com.hk

HUNGARY

Dometic Zrt. Sales Office
Kerékgyártó u. 5.
H-1147 Budapest
☎ +36 1 468 4400
📠 +36 1 468 4401
Mail: budapest@dometic.hu

ITALY

Dometic Italy S.r.l.
Via Virgilio, 3
I-47122 Forlì (FC)
☎ +39 0543 754901
📠 +39 0543 754983
Mail: vendite@dometic.it

JAPAN

Dometic KK
Maekawa-Shibaura, Bldg. 2
2-13-9 Shibaura Minato-ku
Tokyo 108-0023
☎ +81 3 5445 3333
📠 +81 3 5445 3339
Mail: info@dometic.jp

MEXICO

Dometic Mx, S. de R. L. de C. V.
Circuito Médicos No. 6 Local 1
Colonia Ciudad Satélite
CP 53100 Naucalpan de Juárez
Estado de México
☎ +52 55 5374 4108
📠 +52 55 5393 4683
Mail: info@dometic.com.mx

NETHERLANDS

Dometic Benelux B.V.
Ecustraat 3
NL-4879 NP Etten-Leur
☎ +31 76 5029000
📠 +31 76 5029019
Mail: info@dometic.nl

NEW ZEALAND

Dometic New Zealand Ltd.
Unite E, The Gate
373 Neilson Street
Penrose 1, Auckland
☎ +64 9 622 1490
📠 +64 9 622 1573
Mail: customerservices@dometic.co.nz

NORWAY

Dometic Norway AS
Østerøyveien 46
N-3232 Sandefjord
☎ +47 33428450
📠 +47 33428459
Mail: firmapost@dometic.no

POLAND

Dometic Poland Sp. z o.o.
Ul. Pulawska 435A
PL-02-801 Warszawa
☎ +48 22 414 3200
📠 +48 22 414 3201
Mail: info@dometic.pl

PORTUGAL

Dometic Spain, S.L.
Branch Office em Portugal
Rot. de São Gonçalo nº 1 – Esc. 12
2775-399 Carcavelos
☎ +351 219 244 173
📠 +351 219 243 206
Mail: info@dometic.pt

RUSSIA

Dometic RUS LLC
Komsomolskaya square 6-1
RU-107140 Moscow
☎ +7 495 780 79 39
📠 +7 495 916 56 53
Mail: info@dometic.ru

SINGAPORE

Dometic Pte Ltd
18 Boon Lay Way 06-140 Trade Hub 21
Singapore 609966
☎ +65 6795 3177
📠 +65 6862 6620
Mail: dometic@dometic.com.sg

SLOVAKIA

Dometic Slovakia s.r.o. Sales Office Bratislava
Nádražná 34/A
900 28 Ivanka pri Dunaji
☎/📠 +421 2 45 529 680
Mail: bratislava@dometic.com

SOUTH AFRICA

Dometic (Pty) Ltd.
Regional Office
South Africa & Sub-Saharan Africa
2 Avalon Road
West Lake View Ext 11
Modderfontein 1645
Johannesburg
☎ +27 11 4504978
📠 +27 11 4504976
Mail: info@dometic.co.za

SPAIN

Dometic Spain S.L.
Avda. Sierra del Guadarrama, 16
E-28691 Villanueva de la Cañada
Madrid
☎ +34 902 111 042
📠 +34 900 100 245
Mail: info@dometic.es

SWEDEN

Dometic Scandinavia AB
Gustaf Melins gata 7
S-42131 Västra Frölunda
☎ +46 31 7341100
📠 +46 31 7341101
Mail: info@dometicgroup.se

SWITZERLAND

Dometic Switzerland AG
Riedackerstrasse 7a
CH-8153 Rümlang
☎ +41 44 8187171
📠 +41 44 8187191
Mail: info@dometic.ch

UNITED ARAB EMIRATES

Dometic Middle East FZCO
P. O. Box 17860
S-D 6, Jebel Ali Freezone
Dubai
☎ +971 4 883 3858
📠 +971 4 883 3868
Mail: info@dometic.ae

UNITED KINGDOM

Dometic UK Ltd.
Dometic House, The Brewery
Blandford St. Mary
Dorset DT11 9LS
☎ +44 344 626 0133
📠 +44 344 626 0143
Mail: customerservices@dometic.co.uk

USA

Dometic RV Division
1120 North Main Street
Elkhart, IN 46515
☎ +1 574-264-2131