



Handwritten signature: nhs make

This program will address the most common system problems associated with the RM2310/241 **6102810** Manual Refrigerators supplied by The Dometic Corporation. Our intent is to provide you with a guideline of checks to make, should you encounter one of the following symptoms.



SYMPTOM	CAUSE	REFER TO SECTION	STEP
1. No AC operation.	Operation AC Volts Heating Element Thermostat Wiring	1.1 2 3 5.4 8.2	
2. No gas operation - no spark.	Operation Piezo Igniter Electrode Wiring	1.1 5.2 5.3 8.2	
3. No gas operation — sparks but no flame.	Operation LP Gas Filter Orifice Burner Safety Valve Thermocouple Thermocouple Adapter	1.1 6 7.1 7.9 7.6 7.3 7.4 7.5	
4. No cooling on any mode.	Operation Ventilation Level Ambient Temperature Cooling Unit	1.1 9.2 9.1 9.4 9.5	
5.  cooling on gas - cools properly on AC and DC	LP Gas Thermostat Filter Orifice Burner Flue Baffle Flue Tube	6 7.2 7.1 7.9 7.6 7.7 7.8	
6. No cooling on AC - cools properly on gas and DC.	AC Volts Heating Element Thermostat Wiring	2 3 5.4 8.2	
7. Insufficient cooling on all modes.	Operation Level Ventilation Ambient Temperature Air Leaks Thermostat Cooling Unit Air Leaks	1.1 9.1 9.2 9.4 9.3 5.4 9. 9.4	

SYMPTOM	CAUSE	REFER TO SECTION	STEP
8. Insufficient cooling on AC - Cools properly on Gas and DC.	AC Volts Heating Element Thermostat	2 3 7.4	
9. Insufficient cooling on gas. Cools properly on AC and DC.	LP Gas Pressure Thermostat Filter Orifice Burner Flue Baffle Flue Tube	6 7.2 7.1 7.9 7.6 7.7 7.8	
10. Won't stay lit on gas.	LP Gas Safety Valve Thermocouple Adapter Flame Indicator Meter Thermocouple Flue Baffle Orifice Burner	6 7.3 7.5 5.6 7.4 7.7 7.9 7.6	
11. No DC operation - cools properly on AC and GAS.	DC Volts Heating Element	4 5.3	
			

SECTION 1
1.1 OPERATION

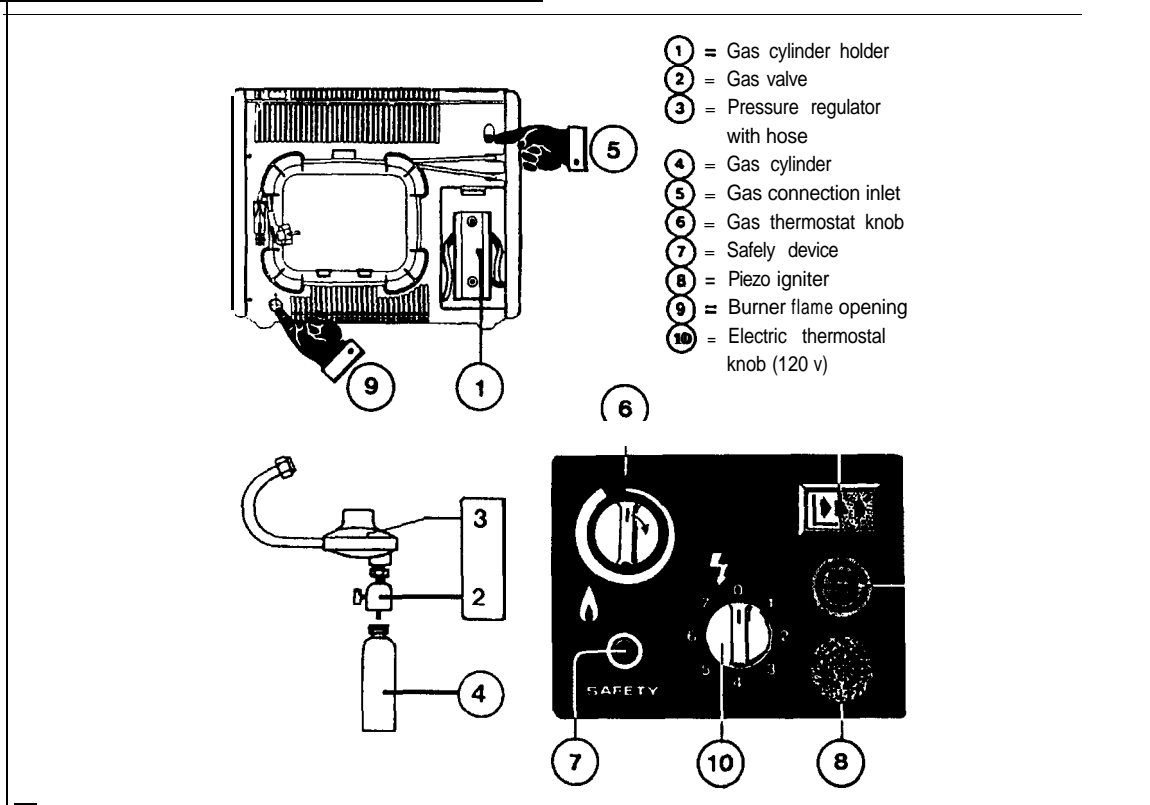

GAS OPERATION

- A. Open Gas cylinder valve (2).
- B. Turn gas thermostat knob (6) in the clockwise direction to MAX setting.
- C. Depress button (7) of flame failure safety device and keep it pressed down for about 20 - 30 seconds, This vents the gas pipe to the burner.
- D. Keep the button (7) of the safety device pressed down and ignite the burner by pressing the piezo-gas lighter button (8) several times.
- E. When the burner is lit, the red pointer of the flame indicator is going from the white into the green field. When the pointer is in the green field, keep knob (7) pushed for another 20-30 seconds, then release it. Check that the pointer remains in the green field. Check the flame visually through the opening (9). If the flame is not burning, repeat ignition procedure.
- F. If, for any reason, the gas flame goes out, the flame safety device works automatically and shuts off the gas supply. While the button (7) is depressed, this device is temporarily inoperative.
- G. When the refrigerator is no longer run on gas, turn off the gas supply at the gas cylinder.

ELECTRIC OPERATION

- A. Check that the gas cylinder valve (2) is turned off.
- B. Connect to the electricity supply with the correct voltage:
For 120 Volt AC operation, turn electric thermostat knob (10) clockwise to position 7.
The 12 Volt circuit is not thermostatically regulated. The knob (10) is useless for this energy source.
NOTE: To stop the electrical 120 Volt AC operation, turn electric thermostat knob (10) counterclockwise beyond the point where a slight resistance is felt, to 0 setting. For safety reasons, disconnect it as well. To stop the electrical 12 Volt DC operation, disconnect voltage supply.

TEMPERATURE REGULATION

After a sufficient period of maximum cooling, set the appropriate thermostat knob to the middle position. The cabinet will now automatically maintain a suitable temperature for ordinary food storage. Usually, no further adjustment will be necessary, but in hot weather, or when more cooling is required, the knob must be turned to a higher position. If less cooling is required, the knob should be turned to a lower position.

SECTION 2

AC VOLTAGE REQUIREMENTS

The refrigerator is a 120-volt AC, 60 Hz appliance. The proper operating range is 100 to 132 volts. Check the AC volts at the receptacle where the refrigerator is attached. If voltage drops below 100 volts, cooling efficiency will decrease with voltage decrease. If voltage is outside of the proper operating range, correct the power source problem.

SECTION 3

AC COMPONENTS

3.1 HEATING ELEMENT

The heating element is designed to deliver a predetermined amount of heat to the cooling unit. To check a heating element, remove the heater leads from the terminal block and measure for proper resistance across the two leads with a properly calibrated ohm meter. This check is to be done with the heating element at room temperature.

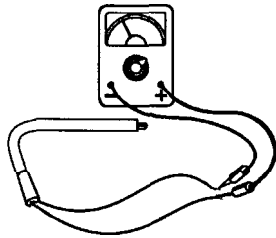

The proper ohms resistance for an RC2000 is 190 with a tolerance range of ten percent. If the resistance is outside the tolerance range, replace the heating element.

SECTION 4

DC VOLTAGE REQUIREMENTS

For proper DC volt operation of the RC2000, operational range should be 10.5 to 15 volts DC. The 12 volt supply is protected by a fuse, located in the control panel. The maximum fuse size is 10 amps. The DC heating element will draw 7 amps at 12 volt DC.

The refrigerator should be run on 12 volt DC only when the car engine is running or the car battery may be drained.

SECTION 5

DC COMPONENTS

5.1 PIEZO IGNITER

The piezo lighter is a self-contained assembly which generally does not need maintenance. When the button is pushed, a spring-loaded striker creates a spark. If there is no resistance when pressing the button, the piezo igniter is defective and must be replaced. If the piezo snaps or has resistance when the button is pushed, but there is no spark, the problem lies in the electrode (see Sec. 5.2)

5.2 ELECTRODE

To check the electrode, first visually inspect it for cracks or breaks on the ceramic insulator. -Also, verify the mounting bracket is attached properly to the electrode. If either of the above conditions are found, replace the electrode. Next, check the spark gap. It must be set at three sixteenths (3/16") of an inch and the tip of electrode above the slots in the burner.

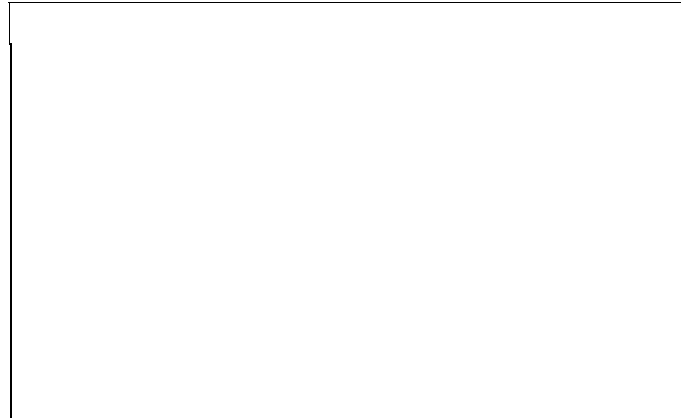

NOTE: If piezo igniter (see Sec. 5.1) is good and there is no spark at the tip of the electrode, **REPLACE THE ELECTRODE.**

5.3 HEATING ELEMENT

The heating element is designed to deliver a predetermined amount of heat to the cooling unit. Check the heating element with ohms resistance using a properly calibrated ohm meter. This check is to be done with the element at room temperature. The proper ohms for the RC2000 is .58 with a tolerance range of ten percent. If the heating element is outside the tolerance range, **REPLACE IT.**

NOTE: It will take a very precise ohm meter to accurately read this measurement. If a precise ohm meter is not available, a continuity reading will indicate an open or complete circuit. If an open circuit is the test result, **REPLACE THE ELEMENT.**

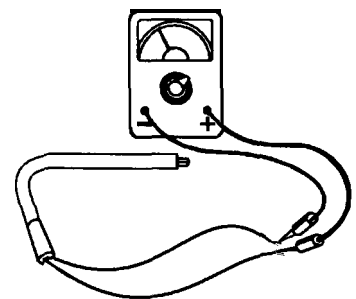

5.4 THERMOSTAT

The thermostat regulates the cabinet temperature by making and breaking the heat source circuit. The internal mechanism breaks contact (continuity) when adequate cabinet temperature has been reached. Check the thermostat for continuity or use a jumper wire with insulated clips and bypass the thermostat.

NOTE: Care should be used. Do not short to thermostat casing. Also, remove the jumper after testing is completed.

If the above test allows the refrigerator to operate, replace the thermostat.

5.5 FUSE

The 12 volt DC supply is protected by a fuse. The fuse holder is fitted into the control panel. The fuse should be a maximum of 10 amp.

To check the fuse, remove from the holder and do a continuity check. If no continuity, replace with a proper amperage fuse.

5.6 FLAME INDICATOR METER

The flame indicator meter is basically a DC volt meter. It reads DC millivolts coming from the thermocouple. If the millivolts from the thermocouple are 5 millivolts or more, the red needle in the meter should be in the green section.

If the blue wire to the meter is shorted to ground, or if the blue and red wires are shorted together, it could cause a flame failure condition.

5.7 LIGHTER PLUG AND CABLE

To check for a complete DC circuit with an ohm meter, put one probe on the center post of the lighter plug and the other probe on one of the side posts of the lighter plug. Continuity should exist. If no continuity exists, check the 10 amp (see Sec. 5.5) the lighter plug and cable and the 12 volt DC heating element (see Sec. 5.3).

To check the lighter plug and cable, first remove the 10 amp DC fuse. Next, check for continuity between the black wire and the center post on the lighter plug. Continuity should exist. Next, check for continuity between the white wire and one of the side posts on the lighter plug. Continuity should exist.

If the continuity readings on the lighter plug and cable are correct, the cable is good - DO NOT REPLACE. If readings are other than above, the cable is defective, REPLACE IT.

SECTION 6 LP GAS REQUIREMENTS

The LP gas pressure to the refrigerator should be 11 inches water column with half of all BTU's of the RV turned on. With all other appliances turned off, the pressure to the refrigerator should not exceed 12 inches water column.

SECTION 7 LP GAS COMPONENTS

7.1 FILTER

A filter is located in the inlet fitting to the thermostat. It protects the internal valve portion of the thermostat by collecting any particles and/or oil that could get into the LP gas line. The filter can become saturated and cause a restriction to gas flow. This could cause a lack of cooling on gas mode. If you suspect a restriction, first verify the thermostat (see Sec. 7.3) is good. If the thermostat is good, and filter is restricted, REPLACE THERMOSTAT.

7.2 THERMOSTAT

On the LP gas mode, full line pressure is directed through the thermostat to the burner until the thermostat senses that the refrigerator cabinet has reached proper cooling temperature. At that time, an internal valve closes and redirects the gas flow through the bypass screw. This reduces the amount LP gas going to the burner assembly. The gas flow remains in this "bypass" mode until the thermostat senses that the refrigerator directs LP gas flow through the thermostat at full line pressure until the cabinet temperature is sufficient. The thermostat is calibrated by the manufacturer so that at mid-range the cabinet temperature should be approximately 40 degrees Fahrenheit. To check the calibration of the thermostat, place a container of water in the cabinet of the refrigerator and operate at mid-range setting until the thermostat is satisfied. Then, check the temperature of the water. It should be approximately 40 degrees. We do not recommend any calibration in the field. If calibration is not correct, REPLACE THE THERMOSTAT.

7.3 SAFETY VALVE

The safety valve is an assembly that shuts off the supply LP gas to the burner if the flame goes out for any reason. This is to ensure that a concentration of unburned gas does not accumulate in the refrigerator vent area. To check the safety valve, use a known good thermocouple (see Sec. 7.6) and install into the safety valve. Next, supply flame to the tip of the thermocouple for 2 to 3 minutes while holding in on the safety valve stem. Next, remove flame from thermocouple tip and release safety valve stem. The safety valve should hold in for at least 30 seconds. If it releases earlier than 30 seconds, REPLACE THE SAFETY VALVE.

7.4 THERMOCOUPLE

The thermocouple is a component extending above the burner assembly so the tip is in the path of the flame. It will produce 5 to 6 millivolts DC on low flame and 9 to 10 millivolts DC on high flame. To check the thermocouple, use a known good safety valve (see Sec. 7.4) and attach to the thermocouple. Next, supply flame to the tip of the thermocouple for 2 to 3 minutes while depressing the safety valve. Remove the flame and release the safety valve. The valve should hold for at least 30 seconds. If it does not hold the safety valve open for 30 seconds, REPLACE THE THERMOCOUPLE. If it does hold for 30 seconds or more, the thermocouple is good, do not replace it.

NOTE: Be sure the tip on the thermocouple is clean.

7.5 THERMOCOUPLE ADAPTER

Located between the thermocouple and the safety valve, the thermocouple adapter is a device that allows the flame indicator meter to read DC millivolts from the thermocouple.

To test the thermocouple adapter, remove it from its location and do a continuity test from the terminal to the center post. Continuity should exist. Next, check for continuity between the terminal and casing. No continuity should exist. If either check is incorrect, REPLACE THE ADAPTER.

7.6 BURNER

The burner is slotted metal tube located below the flue tube on the cooling unit. It should be level and the slots, in the burner, should be directly below the flue tube. The burner should be cleaned periodically, at least once a year. To clean the burner, remove from the refrigerator and check for any foreign residue that could cause a deflection of the gas flow or the flame. Next, soak the burner in an alcohol based solvent and allow to air dry. After cleaning, reinstall in the refrigerator.

7.7 FLUE BAFFLE

The flue baffle is designed to concentrate the heat from the gas flame and direct it to a certain area of the flue tube. It should be cleaned periodically, at least once a year. To clean, remove from the flue tube and check for any damage, then clean thoroughly.

The length of the flue baffle assembly (flue baffle and wire) on the RC2000 is 9-1/2". The flue baffle itself should measure 3/8" long and 9/16" wide. The proper position of the baffle above the burner is 3".

7.8 FLUE TUBE

The flue tube is a component of the cooling unit. It must be cleaned periodically, at least once a year. To clean, remove crossover tube and flue baffle, then cover the burner and clean by using a flue brush. If the flue tube becomes coated with scale or residue from combustion of LP gas, the efficiency of gas operation decreases.

NOTE: After cleaning be sure to reinstall the flue baffle.

7.9 ORIFICE

The orifice is a small brass fitting that has a ruby membrane that is laser-beam drilled and is mounted on the gas line just prior to the burner. The orifice should be cleaned periodically, at least once a year, by using an alcohol based solvent and allowing to air dry. Never use a drill bit or jet tip cleaner to clean any orifice as these devices will damage the factory machined part and create a potentially dangerous condition. The correct orifice for the RC2000 is Size KZ21. **NOTE:** Always use the proper orifice. Never use a larger orifice as this could cause a lack of cooling problem.

SECTION 8 WIRING

8.1 EXTERNAL WIRING

- A. **120 Volts AC Connection:** The refrigerator is equipped with a three-prong (grounded) plug for protection against shock hazards and should be plugged directly into a properly grounded three-pronged receptacle. **DO NOT** cut or remove the grounding prong from this plug.
- B. **12 Volts DC:** The current draw is 7.0 amps. If the refrigerator is run on the car battery it is recommended that the refrigerator be operated only when the car engine is running. If the engine is stopped, the car battery will lose power and become drained.

The 12 V supply is protected by a fuse of maximum 10 amps.

8.2 INTERNAL WIRING

Check all wires and the connectors to ensure a proper and tight connection. Also verify the refrigerator is wired per the wiring diagram for the model you are working on.

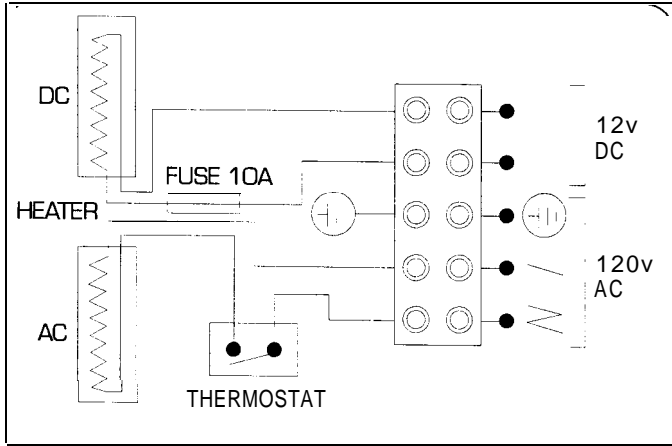

SECTION 9 OTHER

9.1 LEVELING

Leveling is one of the requirements for proper operation with absorption refrigerators. The absorption design utilizes no mechanical pumps or compressors to circulate the refrigerant within the system, so proper leveling must be maintained to provide the correct refrigerant flow. Without proper leveling, refrigerant within the cooling unit will collect and stagnate at certain areas. Without proper refrigerant flow, the cooling process will

stop. The RC2000 refrigerators have a type of cooling unit that utilizes an enclosed pump tube surrounded by a solution to protect the assembly. To ensure proper leveling with these models, the vehicle needs to be leveled (no noticeable sloping of floor or walls). When the vehicle is moving, leveling is not critical as the rolling and pitching movement of the vehicle will pass to either side of level, keeping the refrigerant from accumulating in the piping.

9.2 VENTILATION

Ventilation is one of the requirements for proper cooling unit operation. In a proper installation there should be 0" clearance surrounding the sides, 4" clearance from the rear and 6" clearance from the top of the lid of the refrigerator to achieve proper air flow. In addition, the cooling unit should be at least 1" from the nearest surface made of combustible material.

NOTE: Refrigerators should be installed in accordance with appropriate installation instructions received with the refrigerator.

9.3 AIR LEAKS

Check the gasket on the doors to be sure of a positive air seal. A simple method to check gaskets is to close the door on a dollar bill, then pull the dollar bill out. If no resistance is felt, the gasket is not sealing properly. This should be done on all four sides of the door. If a gasket is not sealing properly, first warm the gasket material with a hair drier.

! CAUTION

DO NOT OVERHEAT
AS YOU CAN MELT THE MATERIAL.

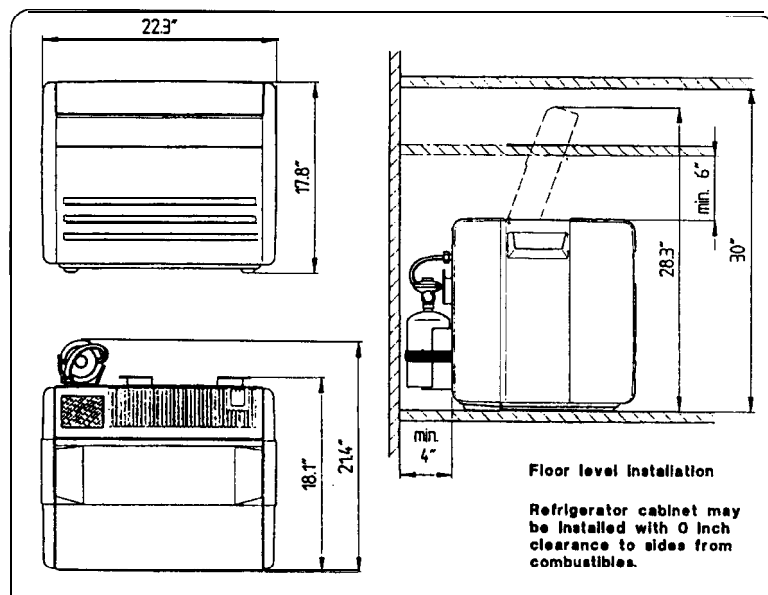

Then close the door and the magnetic strip should pull the gasket to the metal frame. Leave door closed until the material has cooled. Then recheck for a positive seal. If a positive seal cannot be achieved, replace the door gasket. Also check that the cooling unit is installed properly. The cooling unit's foam block, the portion that surrounds the evaporator coils, must be flush to the cabinet at the back of the refrigerator and have a positive seal. If the cooling unit is not installed properly, remove and install properly.

NOTE: Air leaks will cause insufficient cooling as well as rapid formation of frost.

9.4 AMBIENT TEMPERATURE

This is the temperature surrounding the vehicle, as well as the temperature of air at the back of the refrigerator. As the ambient temperature increases, the air temperature in the area of the cooling unit increases. Improper venting at this point, will cause the cooling unit to have reduced efficiency.

9.5 COOLING UNIT

The cooling unit is a self-contained, hermetically sealed set of coils where the refrigeration process takes place. The chemicals involved in the cooling process include hydrogen, ammonia, water and a rust inhibiting agent. There are no repairs recommended on the cooling unit. If it is defective, replace with a new cooling unit.

To check the cooling unit, first verify the AC heating element is good (see Sec. 3). Then place approximately one-half gallon of water inside the refrigerator and place a thermometer in the container of water. Next, supply 115 volts direct to the AC heating element and operate for at least 12 hours. Then check the temperature on the thermometer. It should be at 45 degrees or lower depending on test conditions (see Sec. 9.2 and 9.4). If so, the cooling unit is good. If the temperature of the water is above 45 degrees, replace the cooling unit.

9.6 FOOD STORAGE

Proper refrigeration requires free air circulation within the food storage compartment. Restricted air circulation within this compartment will cause higher cabinet temperatures. To remedy this situation, simply rearrange your food items.

Odorous or highly flavored foods should always be stored in covered dishes, plastic bags or wrapped in foil or waxed paper to prevent food odors. Vegetables, lettuce, etc. should be covered to retain their crispness. **NEVER PUT HOT FOOD INTO THE REFRIGERATOR.**

To reduce frost formation, cover stored liquids and moist foods and do not leave the door open longer than necessary.

When the refrigerator is heavily loaded, it takes longer to lower the refrigerator temperature, and longer to make ice. A very heavy load may also cause defrosting.

9.7 HIGH HUMIDITY

High humidity may cause a small amount of condensation to form on the frame of the refrigerator. In some cases it can develop to such a degree that it will run off the frame. As the humidity is reduced, the sweating will decrease. High humidity can also be a factor in rapid formation of frost.

CONTENTS	PAGE NO.
RC2000 DIAGNOSTIC FLOW CHART	1
<hr/>	
SECTION 1	
OPERATION	
1.1 Operation	3
<hr/>	
SECTION 2	
AC VOLTAGE	
AC VOLTAGE REQUIREMENTS	4
<hr/>	
SECTION 3	
AC COMPONENTS	
3.1 Heating Element	4
<hr/>	
SECTION 4	
DC VOLTAGE	
DC VOLTAGE REQUIREMENTS	4
<hr/>	
SECTION 5	
DC COMPONENTS	
5.1 Piezo Igniter	4
5.2 Electrode	4
5.3 Heating Element	4
5.4 Thermostat	4
5.5 Fuse	5
5.6 Flame Indicator Meter	5
5.7 Lighter Plug	5
<hr/>	
SECTION 6	
LP GAS	
LP GAS REQUIREMENTS	5
<hr/>	
SECTION 7	
LP GAS COMPONENTS	
7.1 Filter	5
7.2 Thermostat	5
7.3 Safety Valve	5
7.4 Thermocouple	6
7.5 Thermocouple Adapter	6
7.6 Burner	6
7.7 Flue Baffle	6
7.8 Flue Tube	6
7.9 Orifice	6
<hr/>	
SECTION 8	
WIRING	
8.1 External Wiring	6
8.2 Internal Wiring	7
<hr/>	
SECTION 9	
OTHER	
9.1 Leveling	7
9.2 Ventilation	7
9.3 Air Leaks	7
9.4 Ambient Temperature	8
9.5 Cooling Unit	8
9.6 Food Storage	8
9.7 High Humidity	8