

**Dometic**

---

**Dometic**  
**ICE MAKER**  
**DIAGNOSTIC SERVICE**  
**MANUAL**

**The Dometic Corporation**

**Corporate Office**

**2320 Industrial Parkway  
Elkhart, IN 46515  
21 g-295-5228**

**Warranty  
Department**

**205 E. Fenn St.  
LaGrange, IN 46761  
219-463-2191**

**Technical Services  
Department**

**509 S. Poplar St.  
LaGrange, IN 46761  
219-463-4858**

# DIAGNOSTIC FLOW CHART

## ICE MAKER FAILS TO START

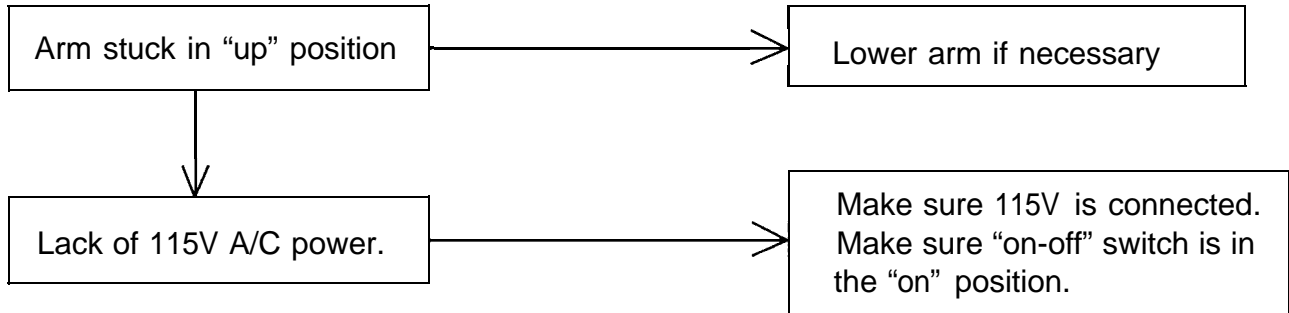

## ICE MAKER WON'T MAKE ICE

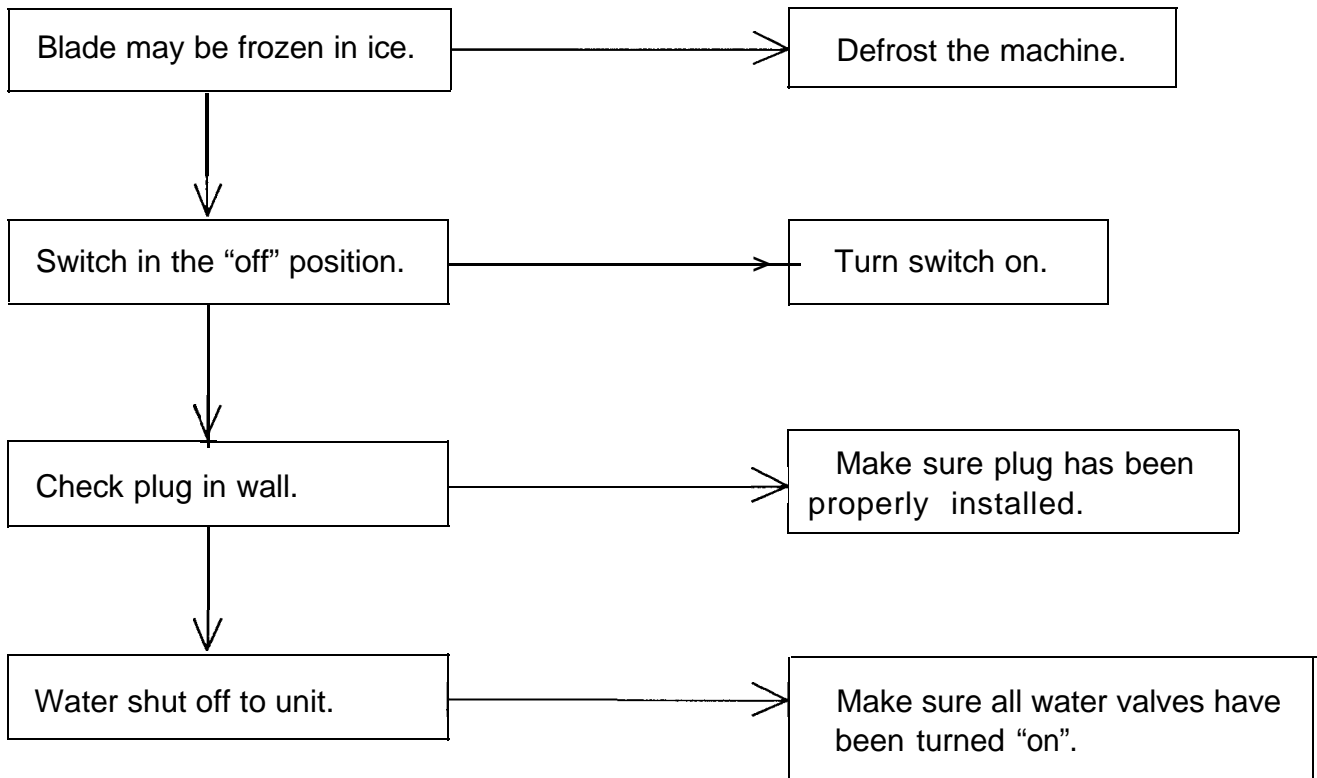

## ICE MAKER FREEZES UP

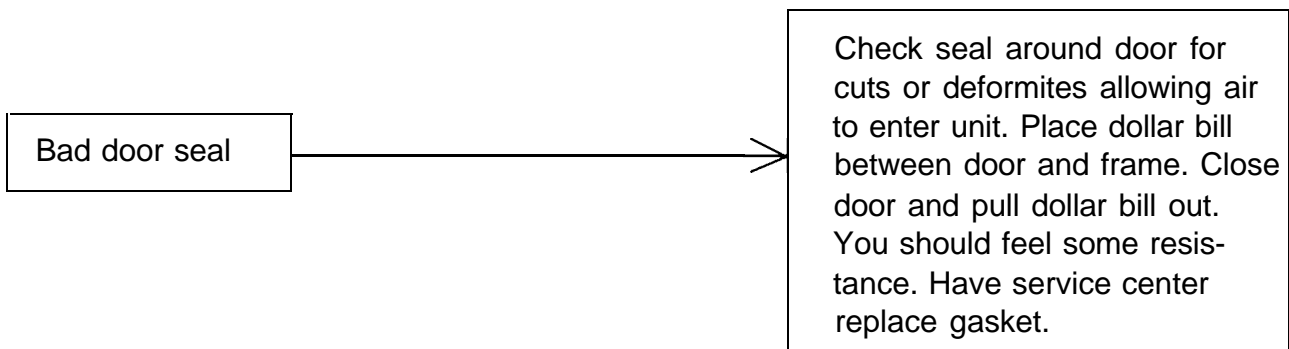

# DIAGNOSTIC FLOW CHART

---

## ICE STICKS TOGETHER

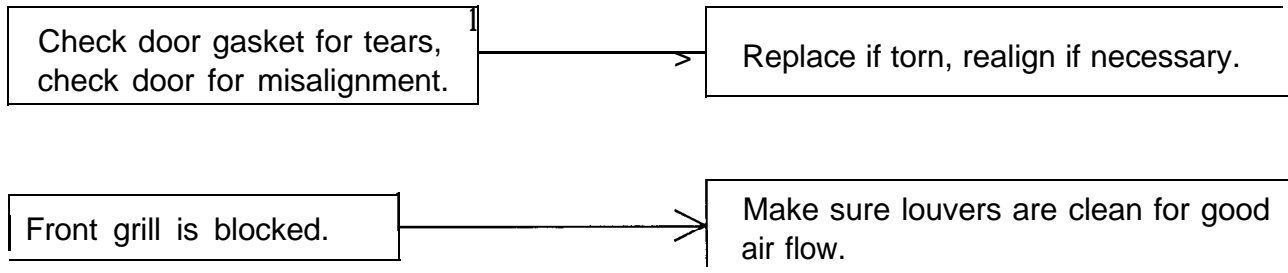

## HAVE TO DEFROST WEEKLY

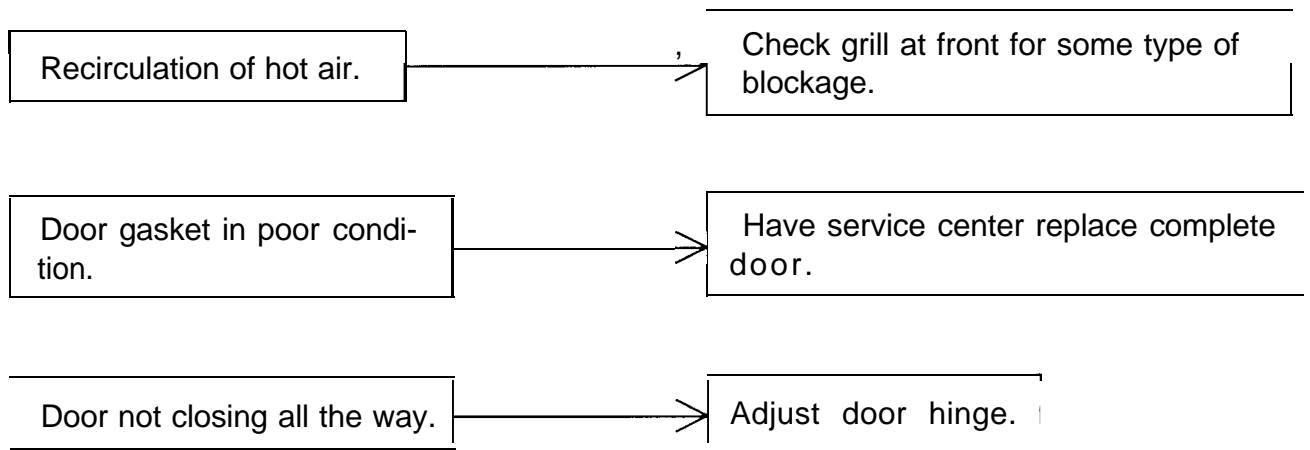

## WATER IN ICE BUCKET

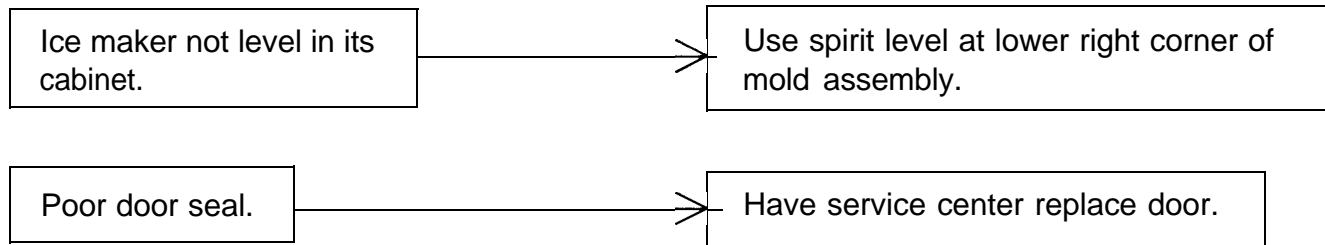

## ICE IS TOO SOFT AND WET

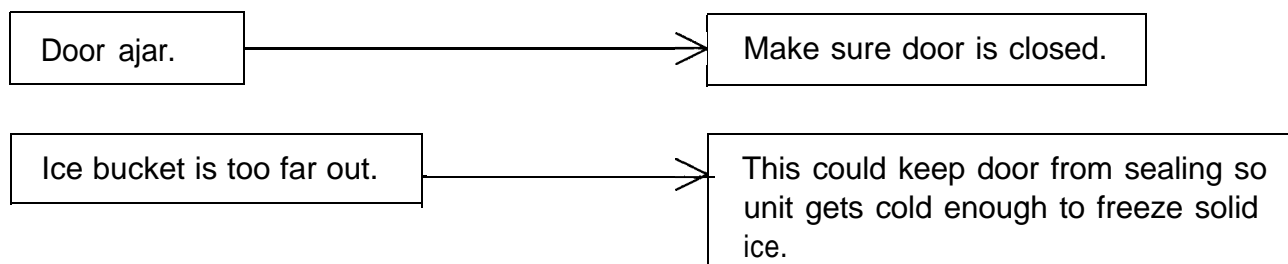

# DIAGNOSTIC FLOW CHART

(Ice is too soft and wet ... continued)

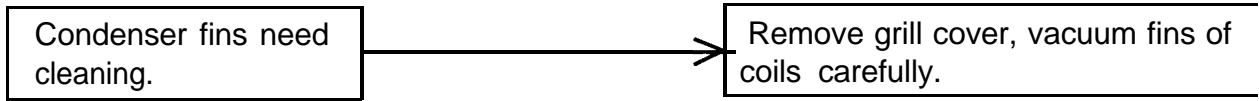

## KEEPS MAKING ICE AND WON'T SHUT OFF

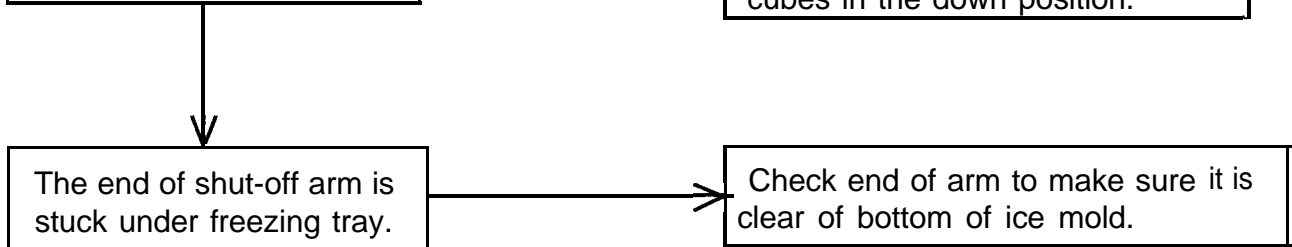
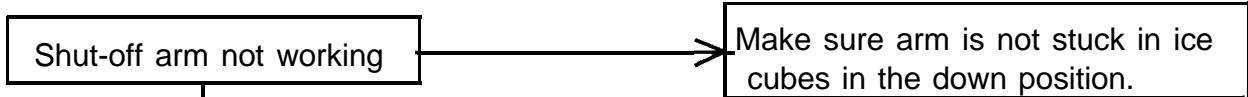

## NOT MAKING ENOUGH ICE

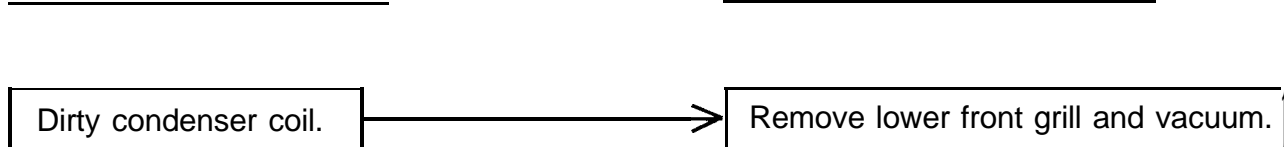
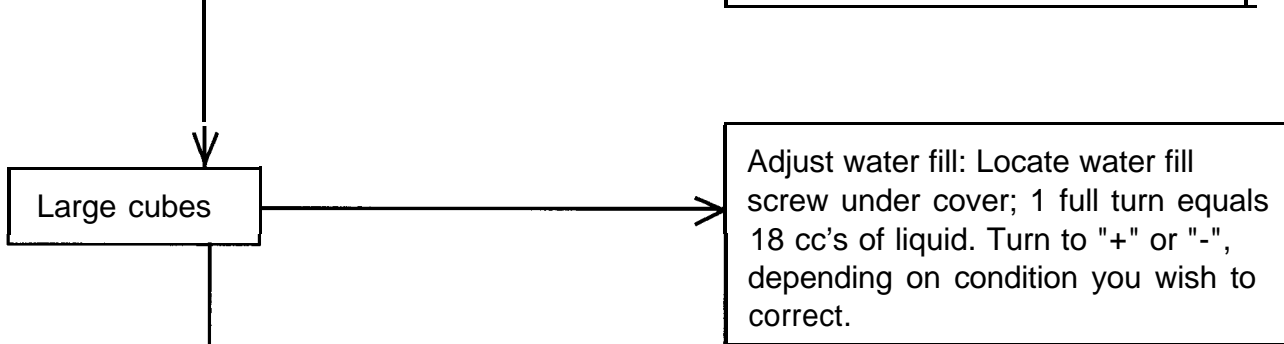
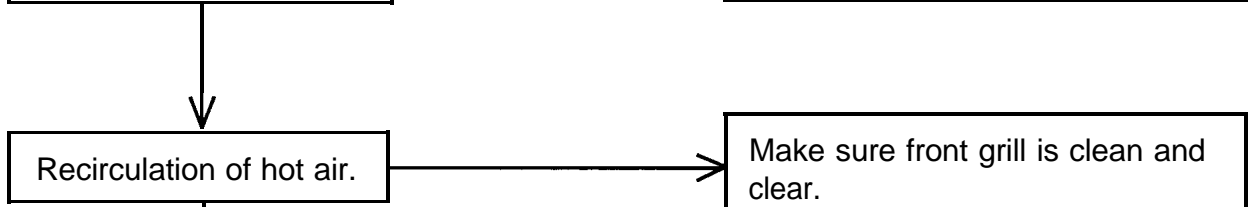
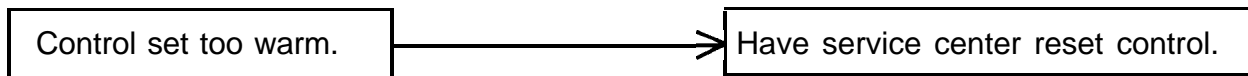

# DIAGNOSTIC FLOW CHART

---

## TOO MUCH WATER COMING IN

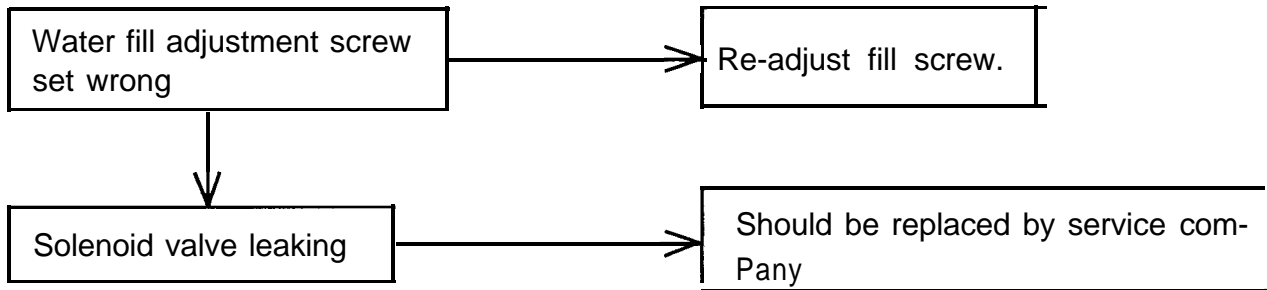

## EJECTOR BLADE FROZEN INTO ICE CUBES

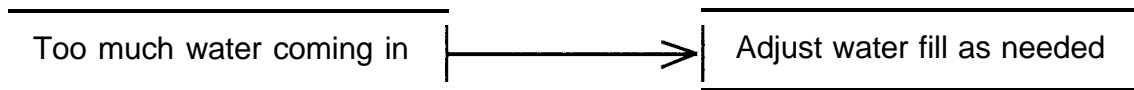

## CUBES STICK TOGETHER

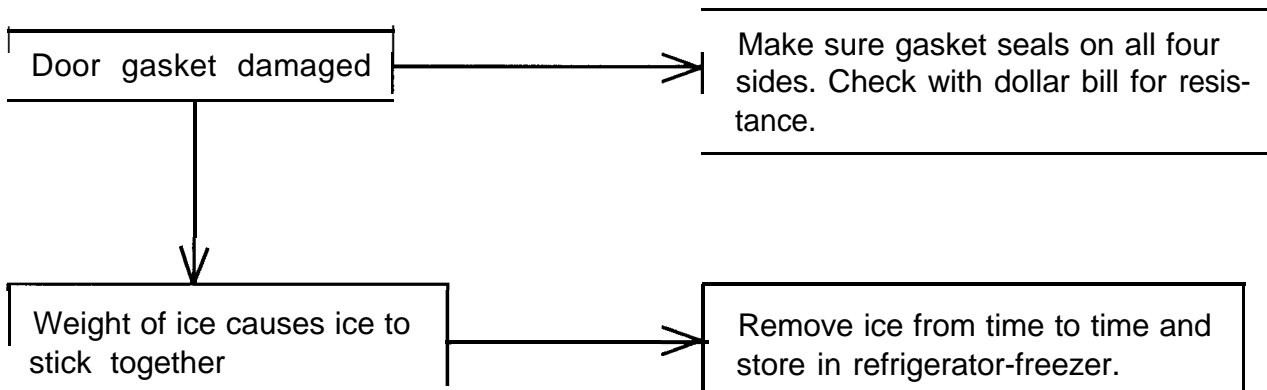

## UNIT IS HOOK-UP BUT NO WATER COMES IN

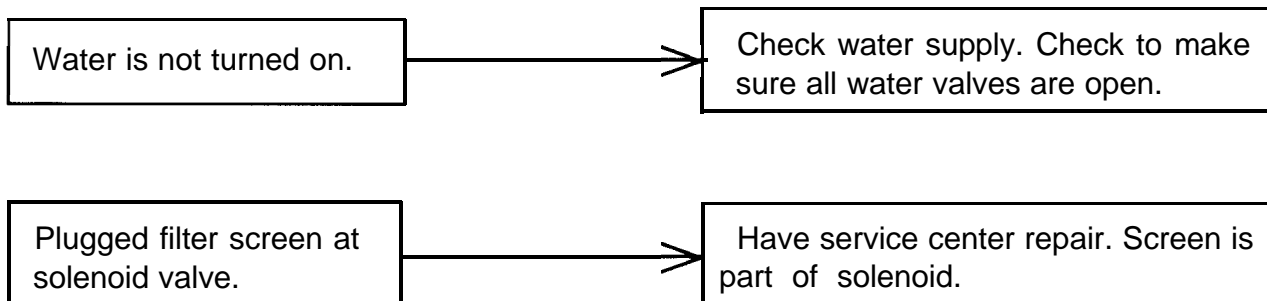

# DIAGNOSTIC FLOW CHART

---

## ICE MAKER IS RUNNING BUT WON'T MAKE ANY CUBES

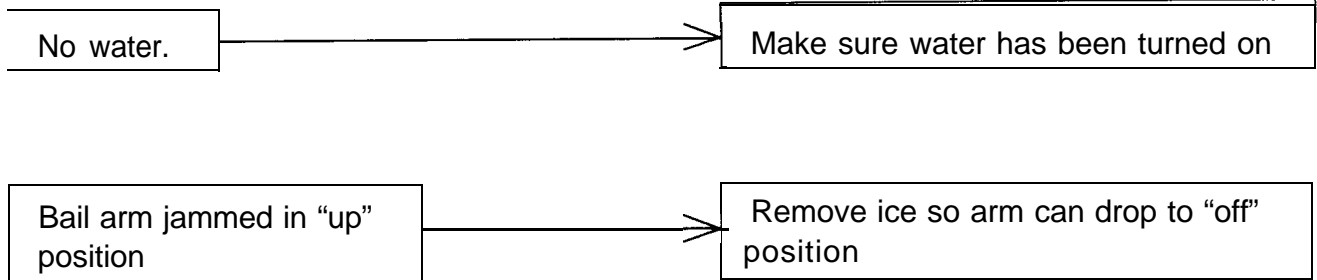

## UNIT WILL NOT EJECT ICE



## COMPRESSOR WON'T RUN

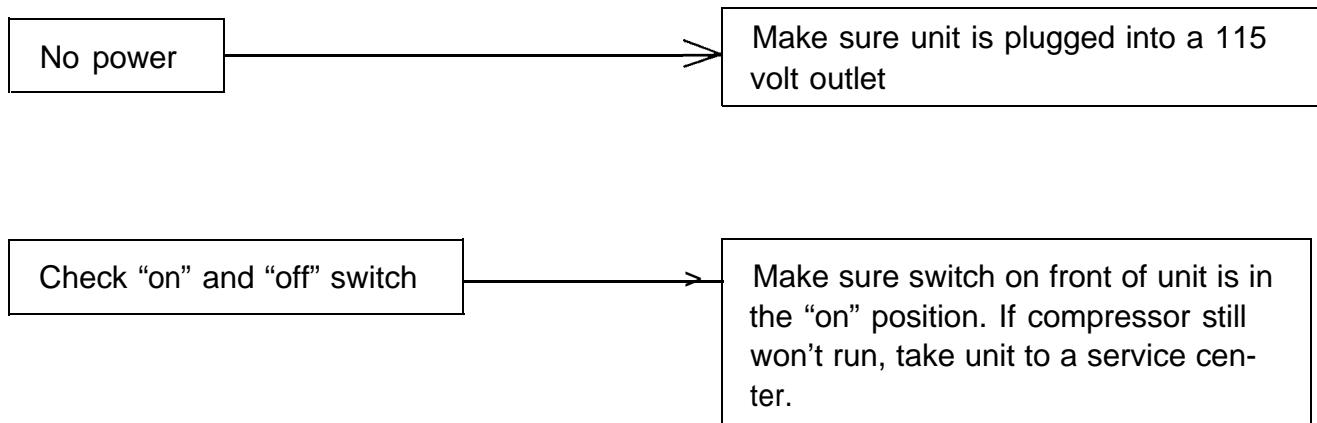

## DOOR NOT CLOSING CORRECTLY

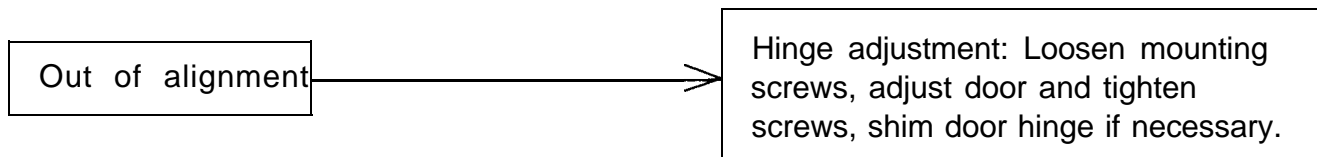

# DIAGNOSTIC FLOW CHART

---

## COMPRESSOR RUNS ALL THE TIME

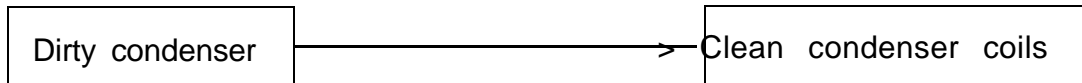
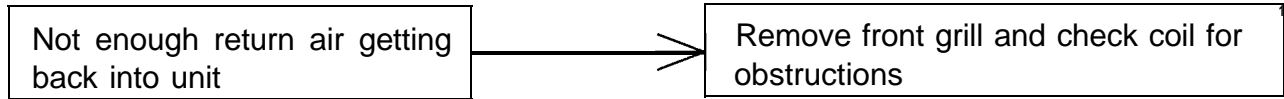

## UNIT LEAKS WATER

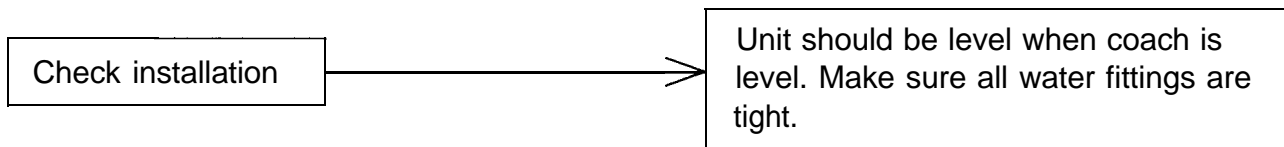

# COMPONENTS

## COMPONENTS

### 1. ICE MOLD

This part is made out of aluminum with separators that mold 12 ice crescents. The thermostat is bonded to the face of this surface.

FIGURE 1 - Ice Mold

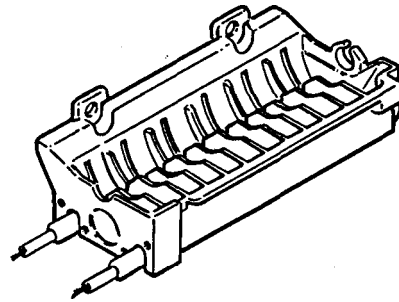

### 2. WATER MOLD

The mold heater uses 165 watts to thaw the ice free from the mold. The heater is in series with the thermostat which also acts as a safety device.

The heater can be serviced separately from the mold. This is done by using four flat-headed retaining screws adjacent to the heater in the mold.

FIGURE 2 - Mold Heater (Staked In Place)

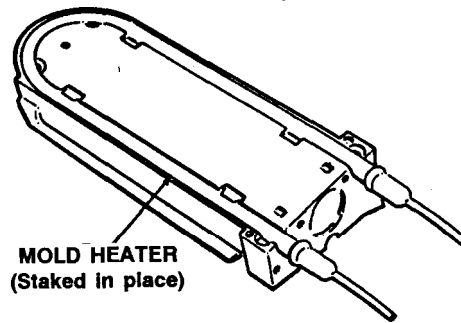

### 3. ICE STRIPPER

This part is attached to the dumping side of the mold. The fingers are used to prevent ice pieces from falling back into the mold.

FIGURE 3 - Ice Stripper

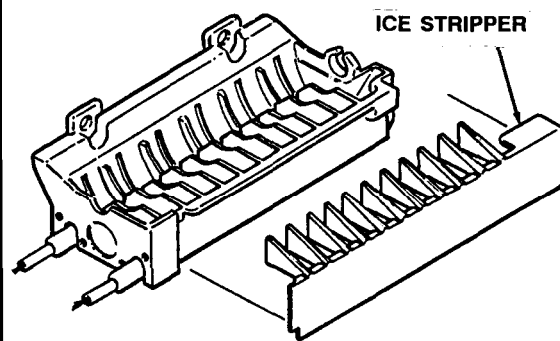

### 4. ICE EJECTOR

The ejector is molded of delzin. Its blades sweep the ice from the mold cavities during the ejection cycle.

The drive end of the ejector is "D" shaped to help create a positive one-way coupling. Both ends are lubricated with silicone grease in the bearing area.

FIGURE 4 - Ice Ejector

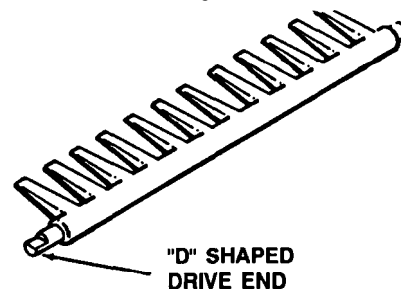



# COMPONENTS

## 5. THERMOSTAT

The thermostat is a single-pole, **single throw**, bi-metal switch. This control starts an ice ejection cycle by closing at  $18^{\circ} \pm 5^{\circ}$ . The rest temperature is  $50^{\circ} \pm 5^{\circ}$ . The thermostat is in series with the mold heater and acts as a safety against overheating in case of mechanical failure.

An aluminum bond is made where the thermostat is mounted against the mold. A gasket is used in this area to prevent water from leaking into the support housing.

FIGURE 5 - Thermostat & Gasket

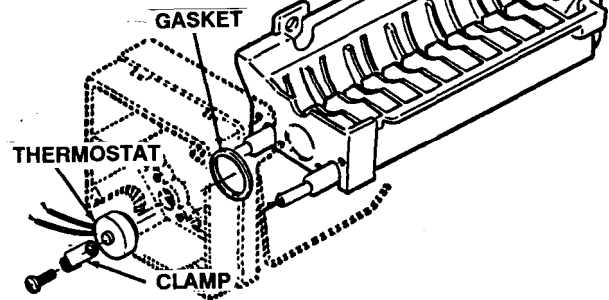

## 6. SHUT-OFF ARM AND LINKAGE

The shut-off arm is cam driven; it operates a switch to control the quantity of ice produced.

During the ejection cycle the arm is raised and lowered during each of the two revolutions of the timing cam. If the shut-off arm comes to rest on top of the ice in the storage bin during either revolution, the switch will remain open and stop the ice maker at the end of that revolution. The arm has a manual shut-off built into the linkage. By raising the arm as high as possible it will lock in that position until forced down.

FIG. 6 Shut-Off Arm

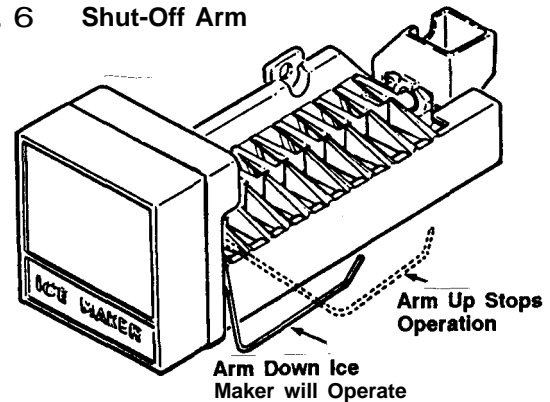

## 7. TIMING SWITCHES

These switches are single-pole, double-throw style. They are identical and can be interchanged. Their functions are:

- Holding Switch - Assures completion of a revolution once the ice maker has started.
- Water Valve - Opens the water valve during the fill cycle. This is the only adjustable component of the ice maker. If you use a double-throw switch, DO NOT use the N.O. terminal.
- Shut-Off Switch - Stops operation when the storage bin is full.

FIG. 7 - Shut-Off Switch

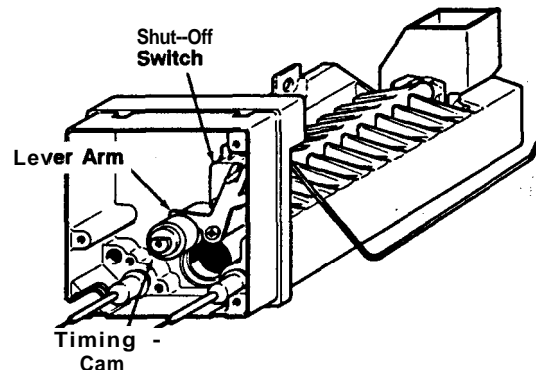

## 8. TIMING CAM AND COUPLER

Three cams are combined into one part. One end is attached to a large timing gear. The other end is coupled to the ejector. They operate in the following manner:

- Inner Cam - Operates shut-off lever arm.
- Center Cam - Operates the holding switch.
- Outer Cam - Operates the water valve switch.

FIG. 6 - Holding & Water Valve Switch

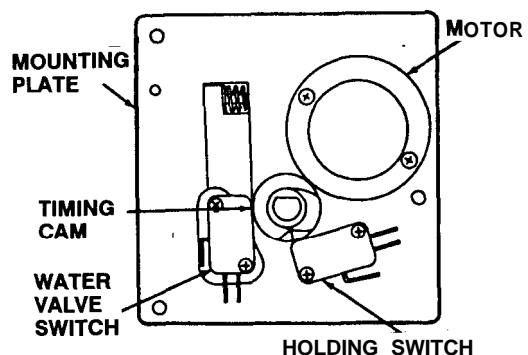

# COMPONENTS

## 9. TIMING GEAR

This gear is driven by the motor and rotates the cam and ejector. The "D" shaped mounting hole attaches to the timing cam. You will find spacer tabs on the backside to prevent binding of the gear and the mounting plate.

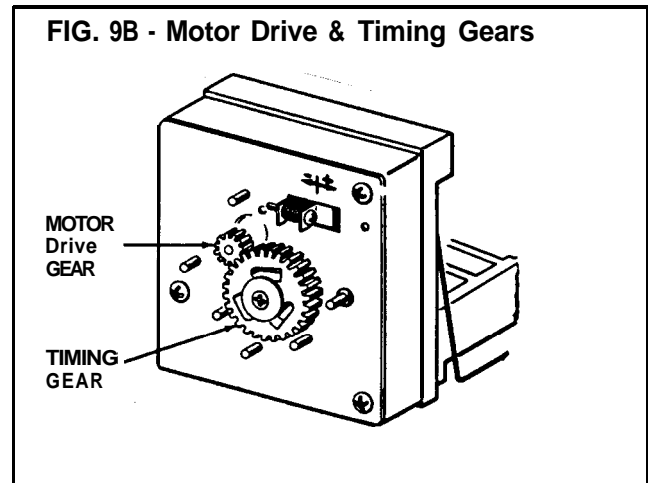
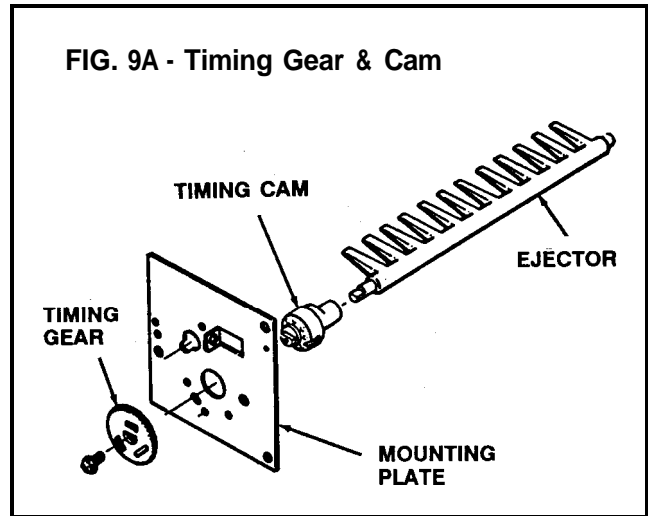

## 10. MOTOR

A low-wattage stall-type motor is used. The gear that is attached turns the timing cam and ejector blades. The RPM of the motor is  $1/3$  or 1 revolution per three minutes.

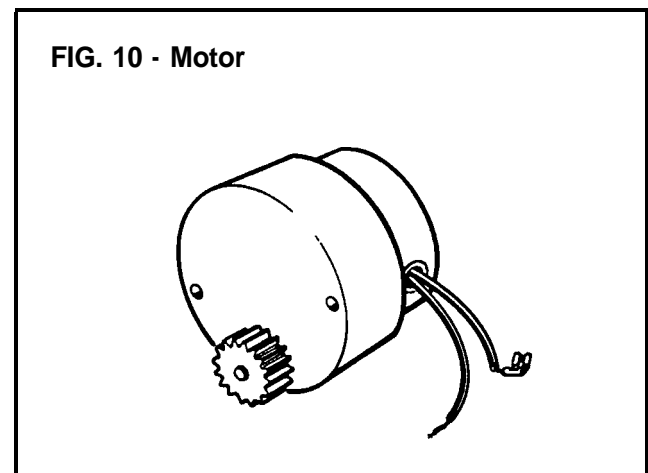

# COMPONENTS

## 11. WATER VALVE

This valve is solenoid operated. When it is open, it releases water from the source to the mold. The amount of water is proportional to the length of time the water valve switch is held closed by its timing cam. The valve has a flow washer inside which acts as a pressure regulator.

It takes 10-15 watts to energize the solenoid coil. The mold heater and coil are in series. This causes the voltage to drop to about 105 VAC at the coil.

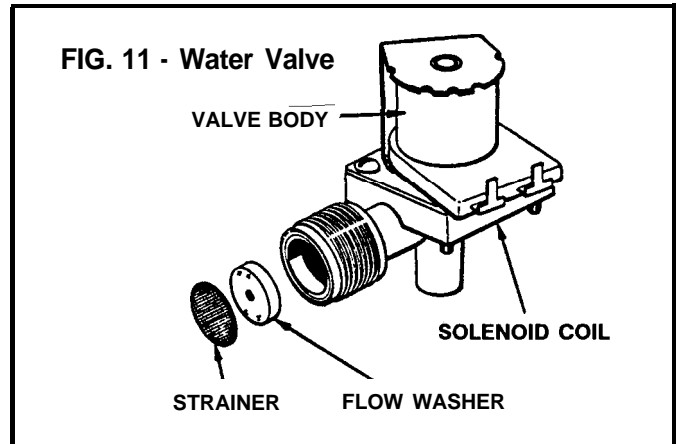

## 12. FILL TROUGH AND BEARING

This is a molded nylon pan. It is used to direct water into the mold. It also supports the inlet tube and forms a bearing for one end of the ejector blade.

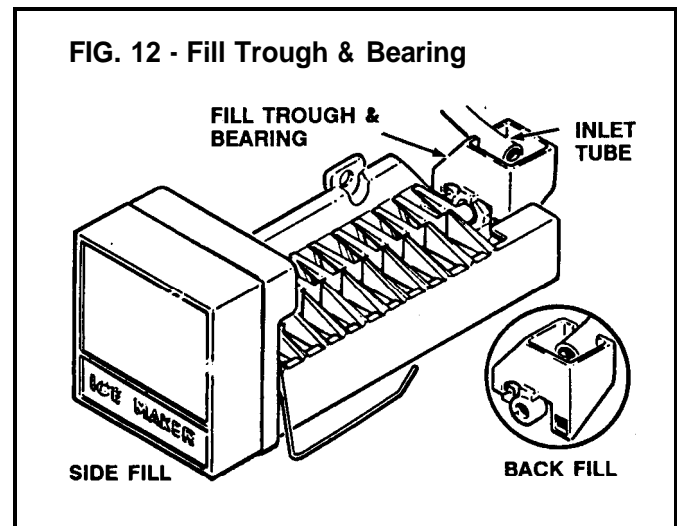

# SCHEMATICS

In the illustration to the right, note the relative position of the components in the following schematics,

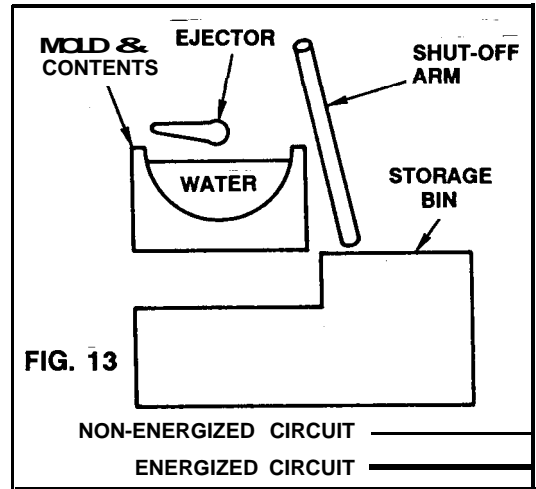

This is a freeze cycle. The mold is filled with water. The thermostat is open. All components are de-energized.

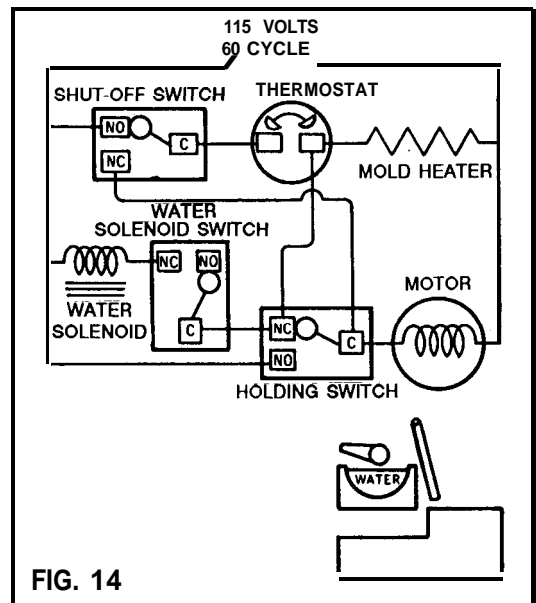

This is the start of an ejection cycle. The thermostat switches to its closed position after being sufficiently cooled by the ice in the mold. The mold heater and motor are now energized. The ejector blades begin to turn.

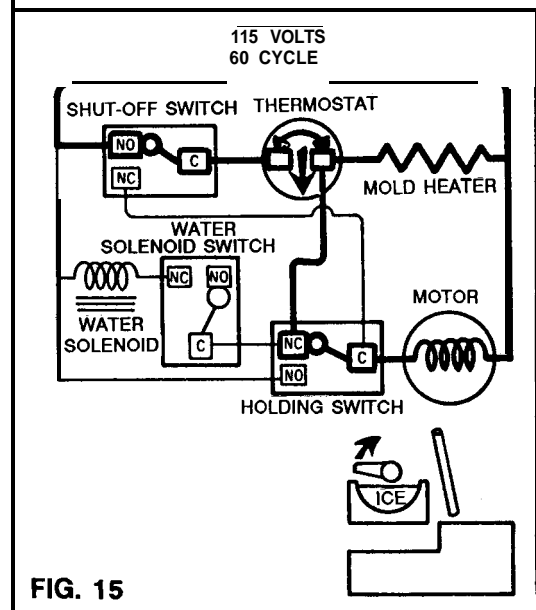

# SCHEMATICS

After a few degrees of motor rotation, the timing cam switches the holding switch to its normally open position; this assures completion of the cycle. The mold heater remains energized through the thermostat circuit. During the first half of the cycle the shut-off arm is raised and lowered by the timing cam and operates the shut-off switch.

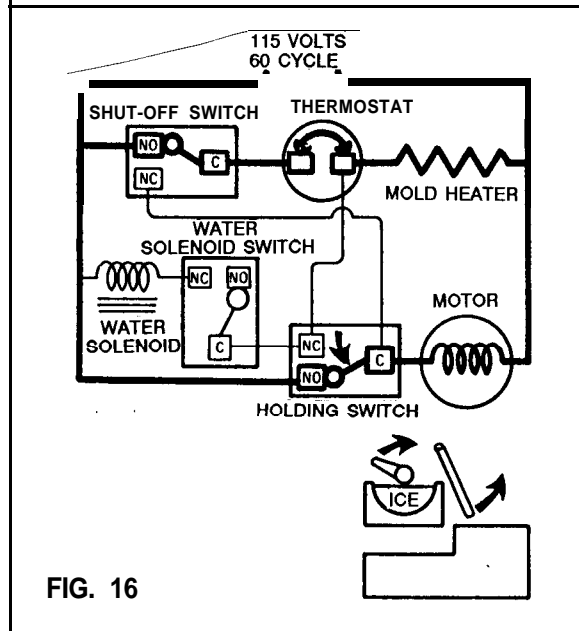

When the ejector blades reach the ice in the mold, the motor will stall. It will remain in this position until the ice has thawed loose. During this time the mold heater remains energized.

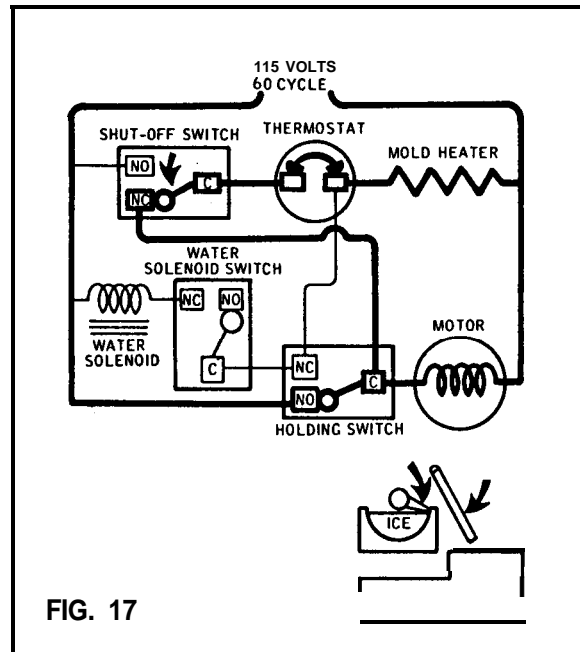

# SCHEMATICS

Near the completion of the first revolution, the timing cam closes the water valve switch. However, since the thermostat is still closed, the mold heater circuit is energized. Current will not pass through the water valve solenoid and its switch. (Electrical current follows the path of the least resistance).

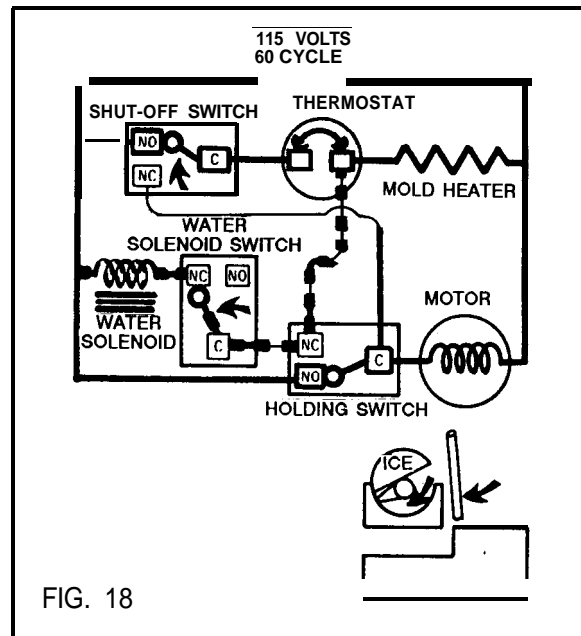

At the end of the first revolution the timing cam opens the holding switch. However, since the thermostat is still closed, a second revolution begins.

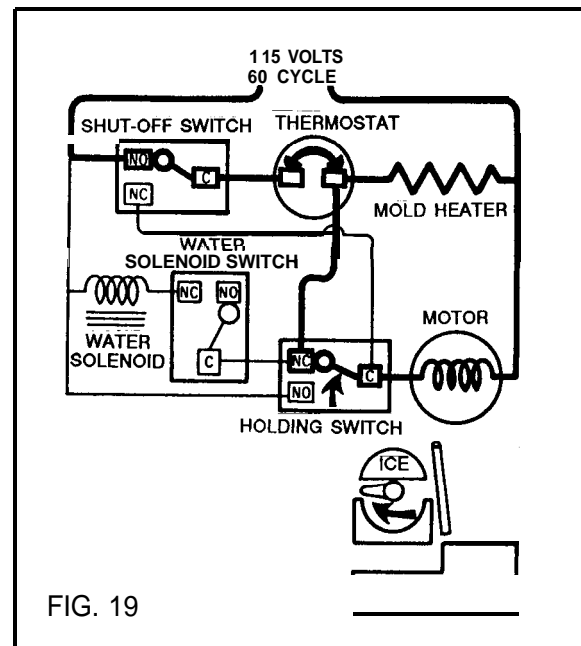

# SCHEMATICS

Once again after a few degrees of rotation the timing cam closes the holding switch providing a circuit to the motor that will assure completion of this revolution. The mold heater remains energized. The shut-off arm will raise and lower again operating its switch. The ice that was ejected during the first revolution is dumped into the storage bin.

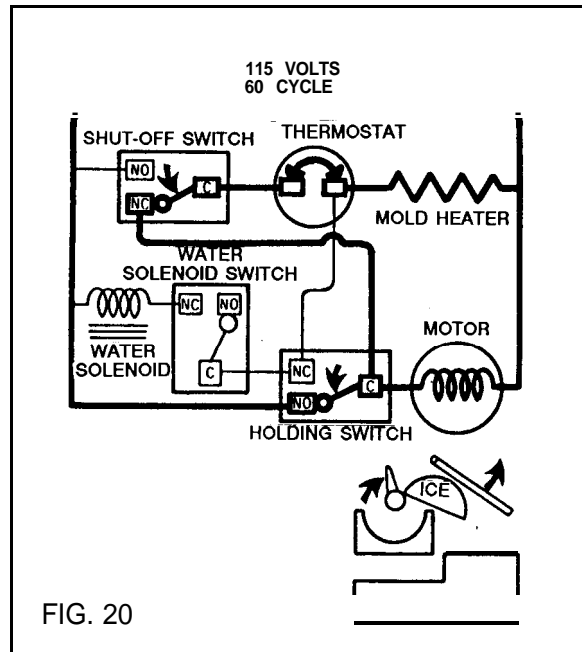

Sometime during the second revolution the mold heater resets the thermostat. At this time, the mold heater is de-energized. If the storage bin is full, the shut-off arm will remain in a raised position.

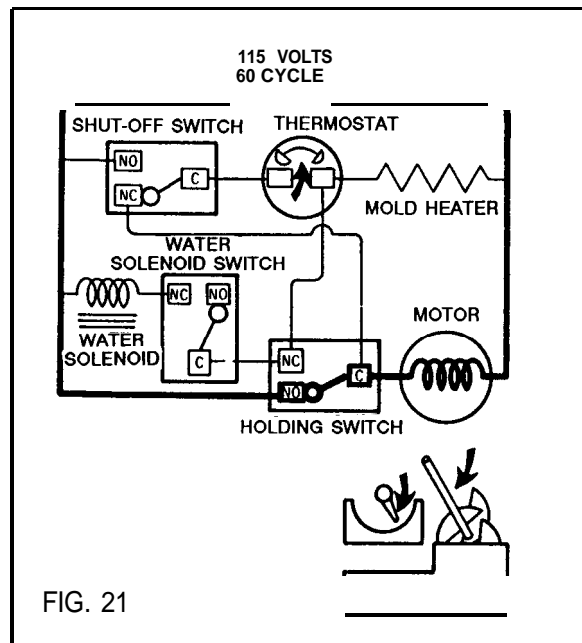

# SCHEMATICS

Near the completion of the second revolution the timing cam again closes the water valve switch. This time a circuit is completed through the water valve solenoid, its switch and the mold heater. The water valve solenoid received about 105 volts. The remaining 10 volts to the mold heater are not noticeable. When the water valve solenoid is energized, the valve opens and water refills the mold.

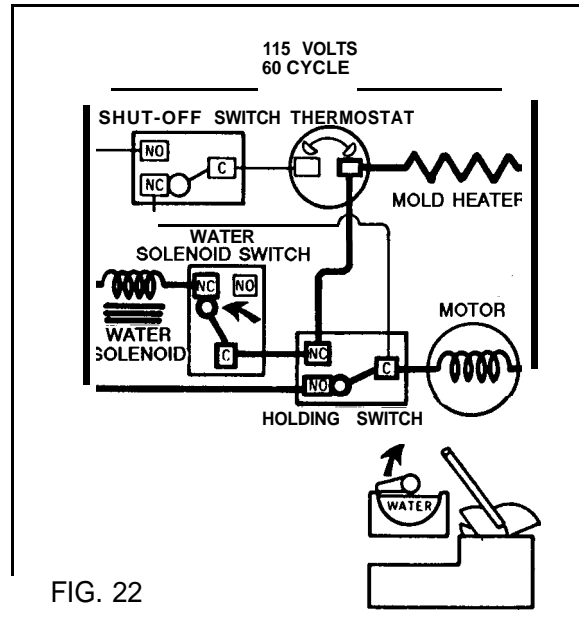

The ejection cycle ends the moment that the holding switch is switched by the timing cam. The water valve switch is also opened. If the storage bin is full, as shown here, additional cycles will not start until sufficient ice is used to lower the shut-off arm, thus operating its switch.

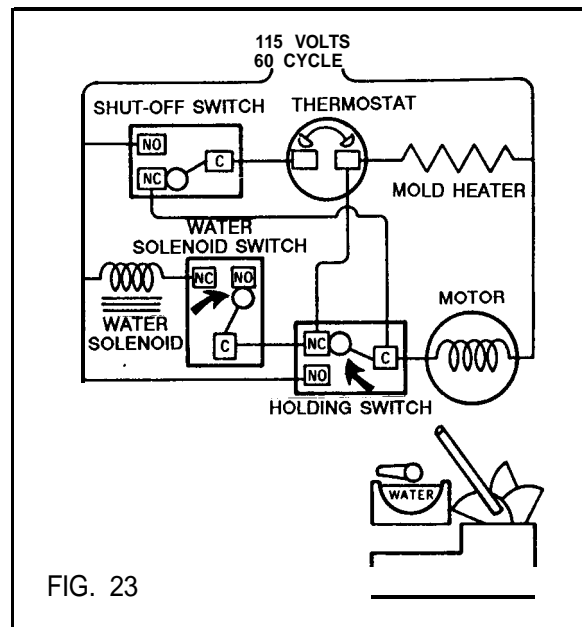



# WIRING DIAGRAM

