

Hercules Power/Control Module

Kit #3316348.900

INTRODUCTION 2

IMPORTANT SAFETY INSTRUCTIONS AND DOCUMENT SYMBOLS 2

 A. Recognize Safety Information. 2

 B. Understand Signal Words. 2

 C. Supplemental Directives 2

 D. General Safety Messages 2

GENERAL INFORMATION 3

INSTALLATION 3

 A. Identifying The Power/Control Module 3

 B. Replacing The Power/Control Module 3

Removing The Integrated Ignition Power/Control Module 3

Removing The Hercules Power/Control Module 4

 C. Installing the Hercules Power/Control Module 4



 **Read these instructions carefully. These instructions MUST stay with this product.**
Dometic Corporation reserves the right to modify product appearances and specifications without notice.

INTRODUCTION

The Hercules Power/Control Module (hereinafter referred to as “unit” or “Product”) is designed and intended as a replacement power/control module for the current model of power/control module installed in Dometic refrigerators in Recreational Vehicles (hereinafter referred to as “RV”).

Dometic Corporation reserves the right to modify appearances and specifications without notice.

IMPORTANT SAFETY INSTRUCTIONS AND DOCUMENT SYMBOLS

This manual has safety information and instructions to help you eliminate or reduce the risk of accidents and injuries.

A. Recognize Safety Information



This is the safety alert symbol. It is used to alert you to potential physical injury hazards. Obey all safety messages that follow this symbol to avoid possible injury or death.

B. Understand Signal Words

A signal word will identify safety messages and property damage messages, and will indicate the degree or level of hazard seriousness.

⚠ WARNING indicates a hazardous situation that, if **NOT** avoided, could result in death or serious injury.

⚠ CAUTION indicates a hazardous situation that, if **NOT** avoided, could result in minor or moderate injury.

NOTICE is used to address practices **NOT** related to physical injury.

C. Supplemental Directives



Read and follow all safety information and instructions to avoid possible injury or death.

Read and understand these instructions before [installation / use / service / maintenance] of this product.

Incorrect [installation / operation / service / maintenance] of this product can lead to serious injury.

The installation **MUST** comply with all applicable local or national codes, including the latest edition of the following standards:

U.S.A.

- ANSI/NFPA70, National Electrical Code (NEC)
- ANSI/NFPA 1192, Recreational Vehicles Code

CANADA

- CSA C22.1, Parts I & II, Canadian Electrical Code
- CSA Z240 RV Series, Recreational Vehicles



Indicates additional information that is not related to physical injury.

D. General Safety Messages

⚠ WARNING Failure to obey the following warnings could result in death or serious injury:

- This product **MUST** be [installed / serviced] by a qualified service technician.
- Do **NOT** modify this product beyond the scope of these service instructions. Modification (beyond these service instructions) can be extremely hazardous.
- **ELECTRICAL SHOCK HAZARD.** Disconnect 120 Vac power from RV. Failure to obey this warning could result in death or serious injury.

NOTICE

- Do **NOT** pinch wiring or allow wiring to rub against sharp edges. If wiring is damaged, it must be replaced by a qualified service technician.
- Disconnect the positive (+) 12 Vdc terminal from supply battery. Protect the disconnected positive terminal, otherwise damage to the unit could occur.

GENERAL INFORMATION

BASIC COMPONENTS

3316348.900 Service Kit

- 3316348.000 Hercules Power/Control Module
- 1 Mounting Screw

REQUIRED TOOLS

Flat Head Screwdriver / Bit

Phillips Screwdriver / Bit

Needle Nose Pliers

INSTALLATION

A. Identifying The Power/Control Module

i If you are replacing power/control module 385071201 with the Hercules Power/Control Module 3316348.000 (3316348.900 Service Kit) pay special attention to the differences in the mounting hardware, mounting location, and operation. Use the supplied kit hardware and this installation manual to mount the replacement unit.

- Before beginning the power/control module replacement, determine what module is being replaced. If you are replacing module 3316348.000 (easily identified by the brass grounding insert in the upper mounting tab), this kit is a direct replacement.

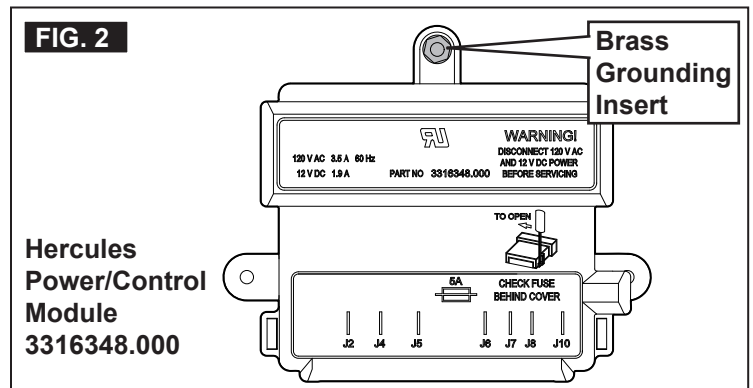
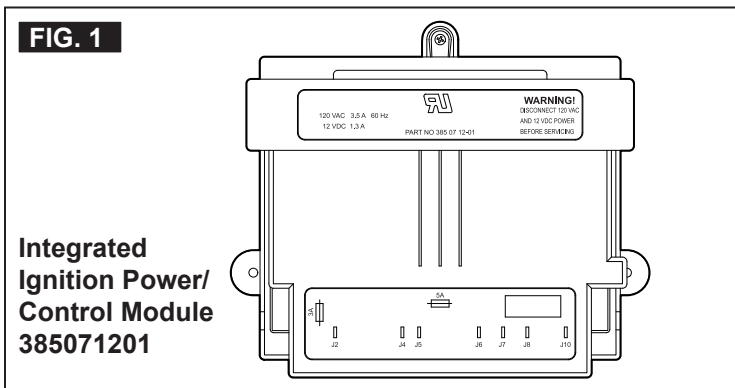

i The new unit is standard on all refrigerators that were factory assembled in the United States after July 2016.

B. Replacing The Power/Control Module

Removing The Integrated Ignition Power/Control Module

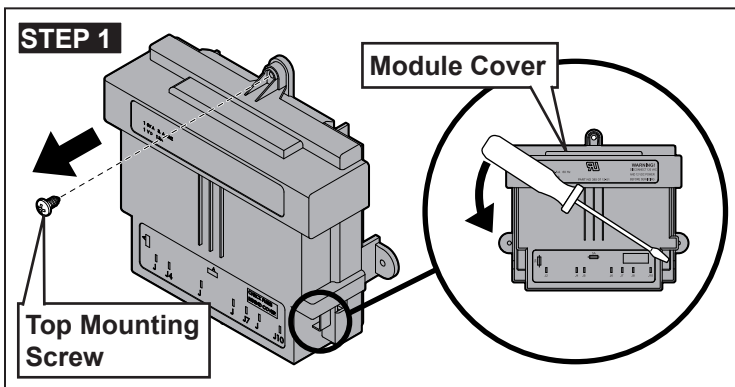

- Remove the top mounting screw and discard.
- Remove the cover using a flat blade screwdriver. Follow the instructions for removal that are molded onto the cover.

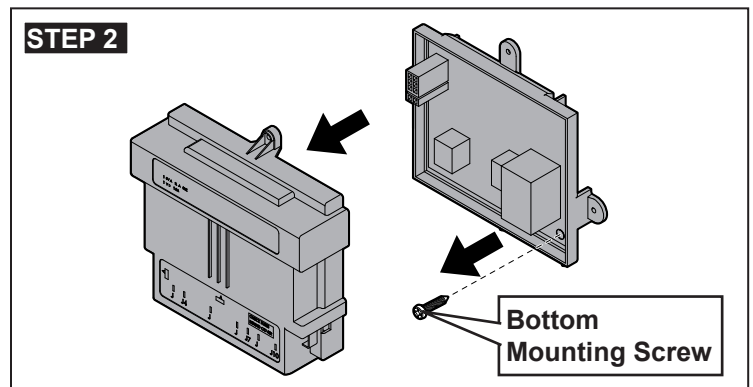

- Disconnect the module wiring by referring to the wiring diagram on the back of the refrigerator.
- Remove the bottom mounting screw and discard.
- Carefully remove the unit from the refrigerator.

INSTALLATION

Removing The Hercules Power/Control Module

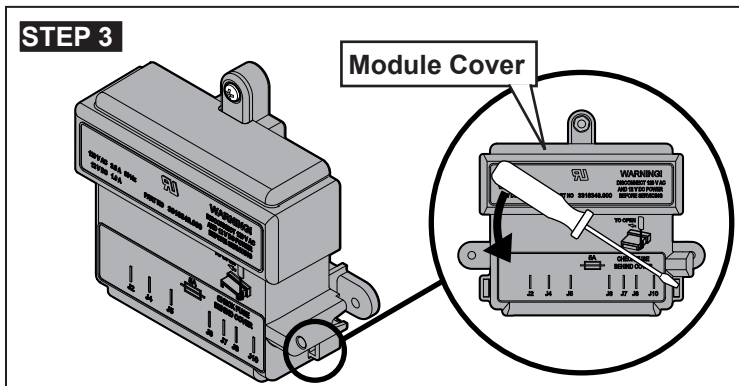

- a. Remove the cover using a flat blade screwdriver. Follow the instructions for removal that are molded onto the cover.

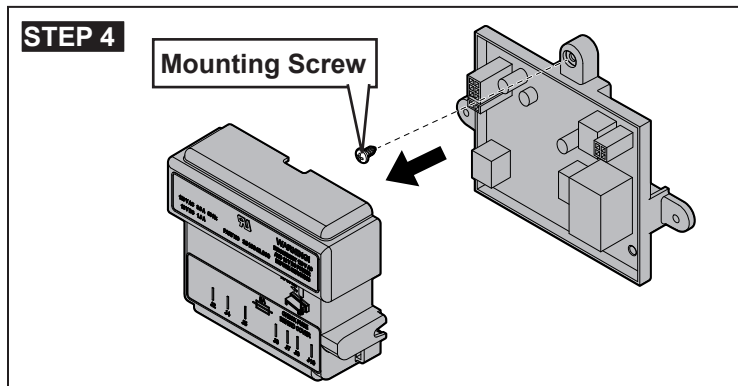

- a. Disconnect the module wiring by referring to the wiring diagram on the back of the refrigerator.
- b. Remove the mounting screw and discard.
- c. Carefully remove the unit from the refrigerator.

C. Installing the Hercules Power/Control Module

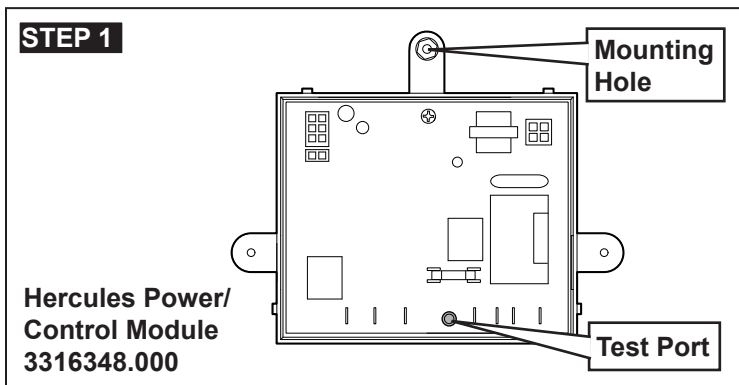

i Do **NOT** attempt to secure the unit by placing a screw in the test port or product damage will occur.

i Only one mounting screw is required to install the Hercules power/control module. Make sure to replace any factory-installed screws with the new mounting screw included in the service kit.

- a. Locate the mounting hole.

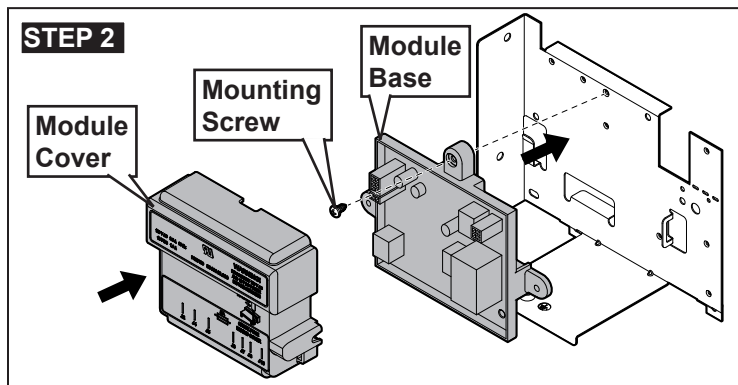

- a. Secure the unit base to the refrigerator using the provided mounting screw.
- b. Reinstall the wiring according to the wiring diagram on the back of the refrigerator.
- c. Snap the power/control module cover onto the base.

i After installation is complete, refer to the Starting the Refrigerator section in the supplied Operating Instructions. Keep the supplied instructions with the refrigerator for future reference.