

TROUBLESHOOTING for COMFORT CONTROL CENTER SYSTEM

INTRODUCTION

The Comfort Control Center control system can be used to operate the following Duo-Therm Units:

- Roof Top Air Conditioners
- Roof Top Heat Pumps
- Basement Air Conditioners
- Basement Heat Pumps
- Dual Basement Air Conditioners
- Dual Basement Heat Pumps
- Other Manufacturer's Furnaces

A majority of air conditioner and heat pump problems are electrical and can be found very easily.

To find a problem in the electrical system, you need to be able to diagnose the following:

- | | |
|--------------------|----------------------------|
| 1. Power Source | 9. Reversing Valve |
| 2. Cable Assembly | 10. PTCR Device |
| 3. Compressor | 11. Heat Strip |
| 4. Capacitors | 12. Cold Control |
| 5. Motors | 13. Ambient Sensor |
| 6. Remote Sensor | 14. Configuration |
| 7. Wiring | 15. Comfort Control Center |
| 8. AC Power Module | 16. DC Voltage |

TOOLS REQUIRED

The air conditioner can be checked with a voltmeter, ohmmeter, clamp-on ammeters and two good thermometers. Some clamp-on ammeters can read voltage and ohms.

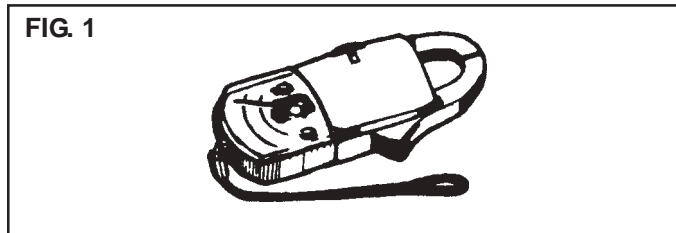

A. QUICK-CHECK TROUBLESHOOTING FOR COMFORT CONTROL CENTER (CCC) CONTROLS

For detailed troubleshooting, refer to section noted.

- 1. Air Conditioner/Heat Pump turned on – No display**
 - a. Reset - Sec. B15
 - b. DC Voltage - Sec. B16
 - c. Cable Assembly - Sec. B2
 - d. AC Control Module - Sec. B8
 - e. Comfort Control Center (CCC) - Sec. B15
- 2. Air Conditioner/Heat Pump turned on – Has display, improper operation**
 - a. Power Source - Sec. B1
 - b. Reset - Sec. B15
 - c. Configuration - Sec. B14
 - d. Wiring - Sec. B7
 - e. AC Control Module - Sec. B8
 - f. Comfort Control Center (CCC) - Sec. B15
- 3. Air Conditioner/Heat Pump turned on – Fan runs, No compressor operation**
 - a. Start Relay/PTCR - Sec. B10
 - b. Start Capacitor - Sec. B5
 - c. Fan/Run Capacitor - Sec. B4
 - d. Cold Control - AC Only, Sec. B12
 - e. Outdoor Ambient Sensor (HP) - Sec. B13
 - f. Compressor - Sec. B3
 - g. Wiring - Sec. B7
 - h. Comfort Control Center - Sec. B15
 - i. AC Control Module - Sec. B8
- 4. Air Conditioner/Heat Pump turned on – Compressor runs, No fan operation**
 - a. Fan/Run Capacitor - Sec. B4
 - b. Motor - Sec. B5
 - c. Wiring - Sec. B7
 - d. Comfort Control Center (CCC) - Sec. B15
 - e. AC Control Module - Sec. B8
- 5. Heat Pump turned on – Compressor runs and fan runs, No heat output**
 - a. Reversing Valve - Sec. B9
 - b. Wiring - Sec. B7
 - c. AC Control Module - Sec. B8

REVISION

Form No. 3108317.029 10/04
(Replaces 3108317.011)
(French 3109134.027)
©2004 Dometic Corporation
LaGrange, IN 46761

B. DETAILED TROUBLESHOOTING FOR COMFORT CONTROL CENTER (CCC) CONTROLS

We will now start electrically troubleshooting Comfort Control Center (CCC) controlled units. The best place to begin is at the power source.

1. POWER SOURCE

If the compressor or fan fails to operate, it is probably not receiving power. Be sure the power cord is plugged in and no fuses or breakers are tripped.

Note: Many customers use extremely long power cords that are undersized. If possible, ask the owner to hook up the RV just like it was when the problem occurred. Make note of the wire size and length of wire. Compare it to the chart for wire sizing.

CURRENT IN AMPS	WIRE SIZE					
	16	14	12	10	8	6
	LENGTH IN FEET					
5	47	76	121	192	216	486
10		38	60	96	153	243
15		25	40	64	102	162
20			30	48	76	121

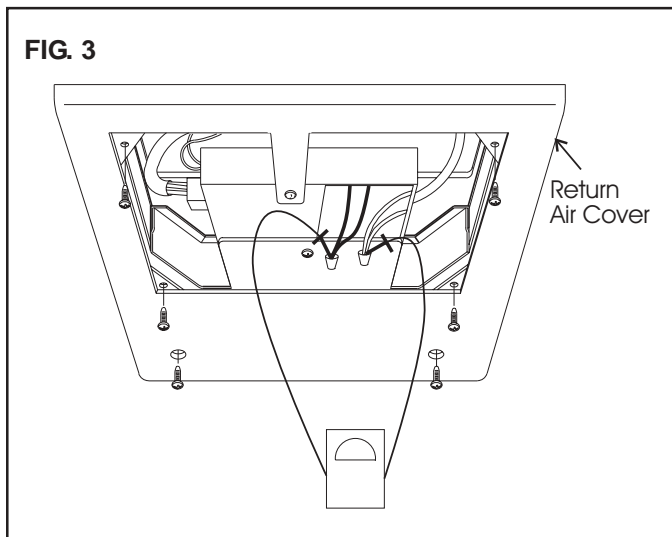
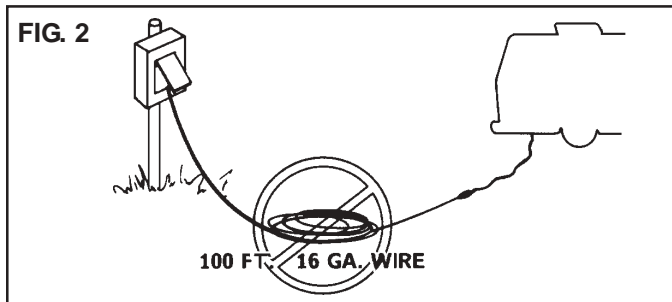

CAUTION

For normal operation of the unit, AC voltage must stay between 108 VAC and 132 VAC. Operation of the unit outside of this voltage range can result in component damage.

To determine if power is reaching the air conditioner, the inside plastic air diffuser box must be removed. The junction box will now be exposed. Remove the cover from the junction box to gain access to the connection between the RV and the unit wires (FIG. 3). Check with a voltmeter for voltage at the connections of the unit to RV wires. **USE CAUTION as 120 volts may be present.** If no voltage is present, the problem is in the coach wiring or breaker/fuse box.

2. CABLE ASSEMBLY

A flat control cable must be routed from the unit to the Comfort Control Center. It must be 26 gauge, stranded copper wire, four (4) conductor (yellow, green, red, and black). The cable must be terminated with a four (4) position telephone RJ-11-6C4P Connector.

Note: Do not use a pre-made telephone extension cable. The order of the connectors is reversed and will cause a failure of the system.

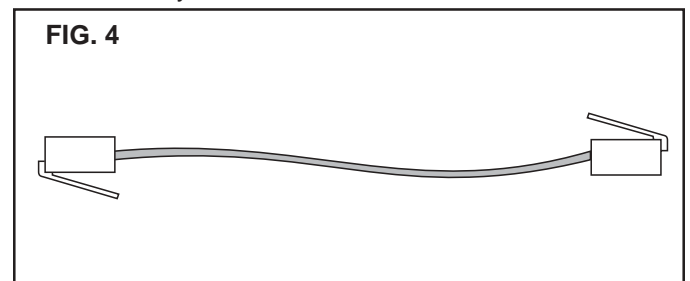

The cable should be made in the following manner:

Cut the control cable to the desired length. When cutting make sure ends are cut straight, not diagonally. Next, use an RJ-11-6C4P connector crimping tool.

FIG. 5
TOP VIEW OF RJ-11-6C4P PLUG

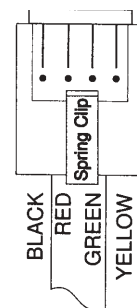

Use the stripper section of the tool to remove the outer insulation of the cable. Be careful not to remove or break the colored insulation of the inner conductors. Repeat on opposite end.

Insert the prepared cable into the RJ-11-6C4P plug. When inserting cable you **MUST** be sure that the black wire is on your left as you look at the top of the plug. See FIG. 5. Insert the RJ-11-6C4P plug into the tool and squeeze to the stop. Repeat the procedure for other end.

The finished cable can be tested with a 3107127.007 comfort control cable tester. See Section B16 for more information on the testing of the cable.

3. COMPRESSOR

The compressor motor can be electrically checked. Be sure to disconnect all power and turn all switches to the “**OFF**” position, before starting to do the tests.

CAUTION

Remove the terminal cover from the compressor and disconnect the three leads connected to the terminals. Make note of the positions so the wires can be replaced correctly.

Use an ohmmeter to check for continuity through the overload device. If no continuity is found and the compressor is hot, allow 15 to 20 minutes for the compressor to cool. If a repeat of the test shows the overload to be open, it is defective and requires replacement.

Continuity should exist between all three terminals of the compressor. If there is no continuity the compressor windings are open and the compressor is defective.

Scrape the compressor casing to bare metal and check continuity from each terminal to the casing. If continuity is found to the casing on any of the terminals, the compressor is shorted and it is defective.

4. CAPACITORS

Duo-Therm Air Conditioners and Heat Pumps use three different capacitors: 1) compressor run capacitor 2) compressor start capacitor and 3) fan/blower capacitor. On some units the compressor run and fan/blower capacitor are in the same case. The compressor run and fan/blower capacitor are housed in a steel or aluminum case. The start capacitor is in a bake-alite or plastic shell. Some have a 15,000 ohm bleeder resistor across the terminals.

The power must be turned “**OFF**” and capacitors must be discharged before making the test. Use an AC voltmeter (set to the highest scale) or a 15,000 ohm 2 watt resistor to bleed away any charge left in the capacitor.

Remove the wires from the terminals and inspect the casing. If it is bulged, cracked or split, the capacitor is defective.

Use an analog voltmeter (dial or hand reading indicator) to test the capacitor after it has been discharged. Set the ohmmeter to mid-range and check for resistance to the case. Any resistance to the case from the terminals indicates it is defective and it needs to be replaced.

Set the ohmmeter to the highest scale and read across the terminals on the capacitor. The ohmmeter should swing towards zero and slowly move back towards infinity. Reverse the leads and repeat the test. If the ohmmeter stays on infinity, it is open and needs to be replaced. If very little meter movement is noticed, switch the meter to a lower scale and repeat test.

The capacitors with the 15,000 ohm resistor should be checked on the 1,000 ohm scale. The ohmmeter should swing below 15,000 ohms and return. Reverse leads and repeat test. If the capacitor does not act as described it is defective and needs to be replaced.

5. MOTORS

To determine if a motor is good, test the windings with an ohmmeter. Disconnect the power supply, and turn all the switches to the “**OFF**” position. Disconnect the motor leads (on some models disconnect the 6 pin plug from the electrical box). The motor should show continuity between all leads and the white wire. Infinity or no continuity indicates the winding is open and the motor is defective.

Check for continuity between the motor frame and each lead. If a continuity reading is present to any lead, the motor is shorted and defective.

The motor can be tested with an ammeter to determine if the operation is within the rating ($\pm 10\%$) listed on the model plate. Many times the motor windings will check good, but bad bearings or capacitor may be found in an ampere test.

6. REMOTE SENSOR

The remote sensor is the temperature sensor that allows the unit for a zone to cycle “**ON**” and “**OFF**” by temperature. A remote sensor is used for each unit or zone. A remote sensor is usually optional for zone 1; but, in some applications the Comfort Control Center is located for convenience of access and the remote sensor placed for temperature control. The proper location of the remote sensor is very important to maintain a comfortable temperature in the RV. The following rules should be observed when selecting a location:

- Locate the remote sensor 54" above the floor.
- Install the remote sensor on a partition, never on an outside wall.
- Avoid locations that are close to doors that lead outside, windows or outside adjoining walls.

- d. Keep them away from discharge from supply registers.
- e. Place them in areas that have good air movement.
- f. Avoid corners and under cupboards.

Unplug the remote sensor and test its cable with an ohmmeter. The ohm reading should be as follows:

TEMPERATURE	OHM READING
55°F	11667
60°F	10212
65°F	8959
70°F	7876
75°F	6939
80°F	6126
85°F	5418
90°F	4802
95°F	4264
100°F	3793

Note: Any ohm reading has a tolerance of plus or minus 10%.

7. WIRING

Mis-wiring or loose wires can cause electrical short or component failure. Use the wiring diagram to verify and correct wiring. Loose terminals should be tightened or replaced.

8. AC POWER MODULE

The AC power module board consists of a relay, dip switches, plug receptacles and other electrical components. If an one of these are defective the **complete AC Control Box** (some models only AC power module) must be replaced. The 3 amp fuse is the only replaceable part on the module board. The board receives messages from the Comfort Control Center, and completes AC circuits to operate the unit. Before diagnosing the AC power module, make sure the configuration, DC and AC voltages and operation is correct.

a. Roof Top Air Conditioners

The operation of the AC control box can be checked at the 6-pin plug connection. Disconnect the unit and use a 120 volt light bulb to check from terminal 5 (the white or common wire) to:

- Terminal 1 (blue) is the compressor
- Terminal 2 (black) is high speed fan
- Terminal 3 (yellow) is medium speed fan
- Terminal 4 (red) is low speed fan
- Terminal 6 (green/yellow) chassis ground

If the circuit is completed the light bulb will illuminate.

Note: Do not use a voltmeter to do the above tests as it will give erroneous readings.

If the circuit is completed to a particular component and that component will not operate, the problem is in the roof top unit.

b. Roof Top Heat Pump

The operation of the AC control box can be checked at the 6-pin plug connection. See FIG. 6. Disconnect the unit and use a 120 volt light bulb to check from terminal 5 (the white or common wire) to:

- Terminal 1 (blue) is the compressor
- Terminal 2 (black) is high speed fan
- Terminal 3 (yellow) reversing valve - this wire is energized in cooling mode only
- Terminal 4 (red) is low speed fan
- Terminal 6 (green/yellow) chassis ground

If the circuit is completed the light bulb will illuminate.

Note: Do not use a voltmeter to do the above tests as it will give erroneous readings.

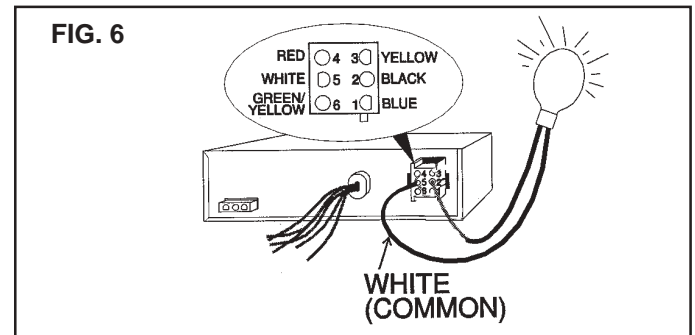

If the circuit is completed to a particular component and that component will not operate, the problem is in the roof top unit.

c. Single Basement Air Conditioners and Heat Pumps

The single air conditioner/heat pump require check out and replacement of the AC power module board only. The diagnosis of the board would be similar to the complete control box except the tests are done directly on the board. See FIG. 7.

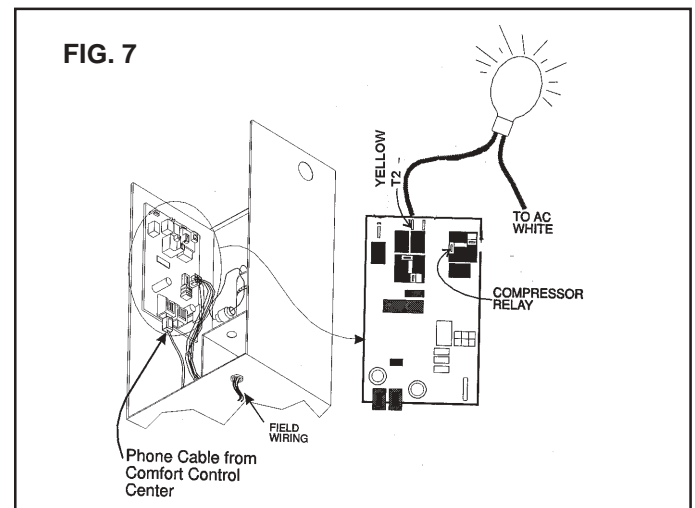

Use an AC light bulb to test if the relays on the board are completing a circuit. Check from the common (white wire) to:

“NO” is a black or blue wire on the compressor relay

- Terminal T1 is a black wire for high fan speed
- Terminal T2 is jumper to T1 terminal on AC's
- Terminal T2 is the reversing valve on heat pumps
- Terminal T3 is a red wire for low fan speed

Note: Do not use a voltmeter to do these checks as it will give erroneous readings.

If the circuit is completed and that component is not operating, the problem is in the wiring to the component.

d. Dual Basement Air Conditioners and Heat Pumps

The operation of the dual air conditioner and heat pump control box can be checked in the same manner as the roof top air conditioner except there are two 9-pin connectors. Disconnect these plugs from the unit. See FIG. 8.

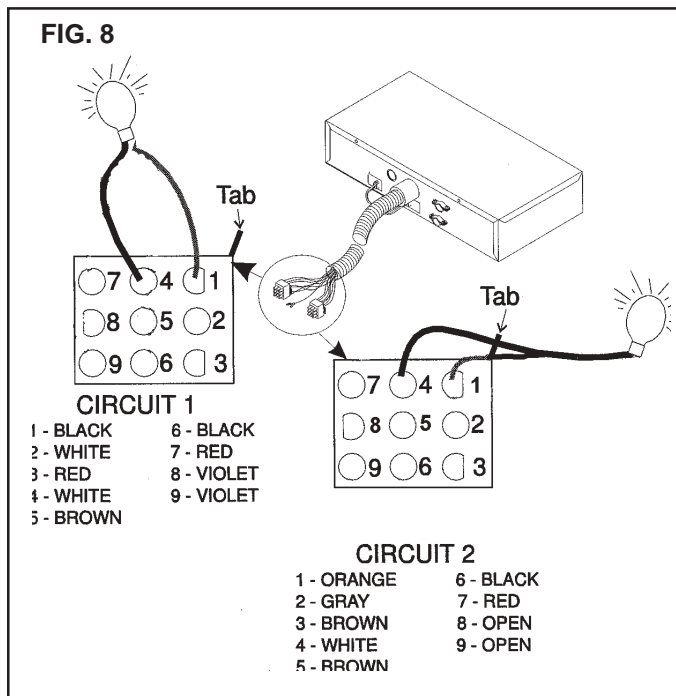

Use a 120 volt AC light bulb to check from Terminal 4 (white wire) common to the other terminals to determine if the circuits are being completed. If the circuit is complete the light will illuminate.

CIRCUIT 1:

- Terminal 1 is a black wire for the compressor.
- Terminal 2 is a white wire and is a run circuit to the compressor. **Do Not Test.**

- Terminal 3 is a red wire and is a start circuit to the compressor. **Do Not Test.**
- Terminal 4 is a white wire and is 120 VAC common.
- Terminal 5 is a brown wire and is the fan capacitor circuit to the fan motor. **Do Not Test.**
- Terminal 6 is a black wire and high speed fan.
- Terminal 7 is a red wire and low speed fan.
- Terminal 8 is a violet wire and is the reversing valve. It is only energized in the heat pump mode in 39424.602 Model.
- Terminal 9 is a violet wire and is 120 VAC common.

Note: Do not use a voltmeter to do these checks as it will give erroneous readings.

CIRCUIT 2:

- Terminal 1 is an orange wire for the compressor.
- Terminal 2 is a gray wire and is the run circuit to the compressor. **Do Not Test.**
- Terminal 3 is a brown wire and is the start circuit to the compressor. **Do Not Test.**
- Terminal 4 is a white wire and is 120 VAC common.
- Terminal 5 is a brown wire and is the fan capacitor circuit to the fan motor. **Do Not Test.**
- Terminal 6 is a black wire and high speed fan.
- Terminal 7 is a red wire and low speed fan.
- Terminals 8 & 9 are open.

Note: The Circuit 2 AC power module board is staged and will have a delay from the Circuit 1 System. Check that Circuit 2 is operational before making tests.

Note: Do not use a voltmeter to do these checks as it will give erroneous readings.

9. REVERSING VALVE

The reversing valve is the heart of a heat pump. It changes the direction of the refrigerant flow through the coils, and changes the system from cooling to heating.

The reversing valve's solenoid can be energized in either the heat or cool mode of operation. Duo-Therm roof top heat pumps have the solenoid energized in the cool mode.

One method of checking the reversing valve is to feel the refrigerant line at the top of the inside coil. In the **COOL** mode, this line will be cool to the touch. In the heat mode the line will be warm or hot to the touch. If you do not feel a cold line in the cooling mode, the direction of flow is not correct.

Check the solenoid coil for ohms resistance. The correct reading is approximately 465 ohms plus or minus 10%.

10. PTCR DEVICE

The positive temperature coefficient resistor (PTCR) has replaced the compressor start relay and in some cases the start capacitor. It should be checked in two different ways:

- Check continuity. Turn "**OFF**" the AC power at the main breaker and Comfort Control Center system switch. Disconnect the PTCR from the circuit. Using an ohmmeter, check for continuity through the PTCR. If there is no continuity the PTCR is open and needs to be replaced.
- The second check is an amp reading. Clamp an ampmeter around the wire from the start capacitor. See FIG. 9

! WARNING

This is an energized circuit. Shock can occur if not tested properly. Testing is to be done by a qualified service technician. Personal injury, property damage or both can occur.

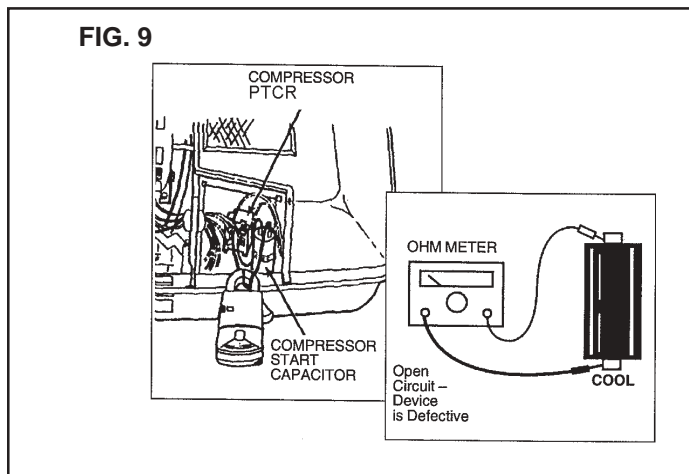

Turn "**ON**" the AC power and set the Comfort Control Center to the cooling mode. When the compressor starts, the ampmeter should show a reading for approximately one second. If there is not an amperage reading or a prolonged reading, the PTCR is faulty and must be replaced.

11. HEAT STRIP

Check the heat strip for continuity across the outside terminals at the heat strip plug. If the circuit is open (no continuity) the fuse link limit or heater element may be defective.

12. COLD CONTROL

(Low Temperature Protection Device)

The cold (freeze) control is used on roof top air conditioners **ONLY**. If used with roof top heat pumps it can cause premature shut off of the compressor.

The cold control is normally open (no continuity), and closed when the temperature is below 41 to 49 degrees. The switch will return to the open position at 52 to 62 degrees.

Check continuity through the switch. In temperatures over 62 degrees, it should show open (no continuity) and in temperatures below 41 degrees it will be closed. Any variation requires the switch to be replaced.

13. AMBIENT SENSOR

The ambient sensor is the outside air temperature sensor and used on heat pumps only. This device allows the heat pump to operate down to 24°F.

To check the ambient sensor, first measure the outside temperature near the sensor. Unplug the sensor (red plug) from the AC power module board. Using an ohmmeter, check the ohms through the ambient sensor on the wire side of the plug.

The temperature reading taken near the ambient sensor should correspond to the readings on the chart below:

TEMPERATURE	OHM READING
55°F	11667
60°F	10212
65°F	8959
70°F	7876
75°F	6939
80°F	6126
85°F	5418
90°F	4802
95°F	4264
100°F	3793

Note: Any ohms reading has a tolerance of plus or minus 10% to be a good component. **A very precise and accurate ohmmeter must be used before replacing the ambient sensor.**

CAUTION

Improper configuration could cause damage to components of the system.

14. CONFIGURATION

The Comfort Control Center configuration relates to setting the dip switches and particular components (remote sensor, cold control, furnace, ambient sensor and load management system) that can be connected to the AC power module board. The Comfort Control Systems can operate up to 4 units for one Comfort Control Center (thermostat) provided the configuration is correct.

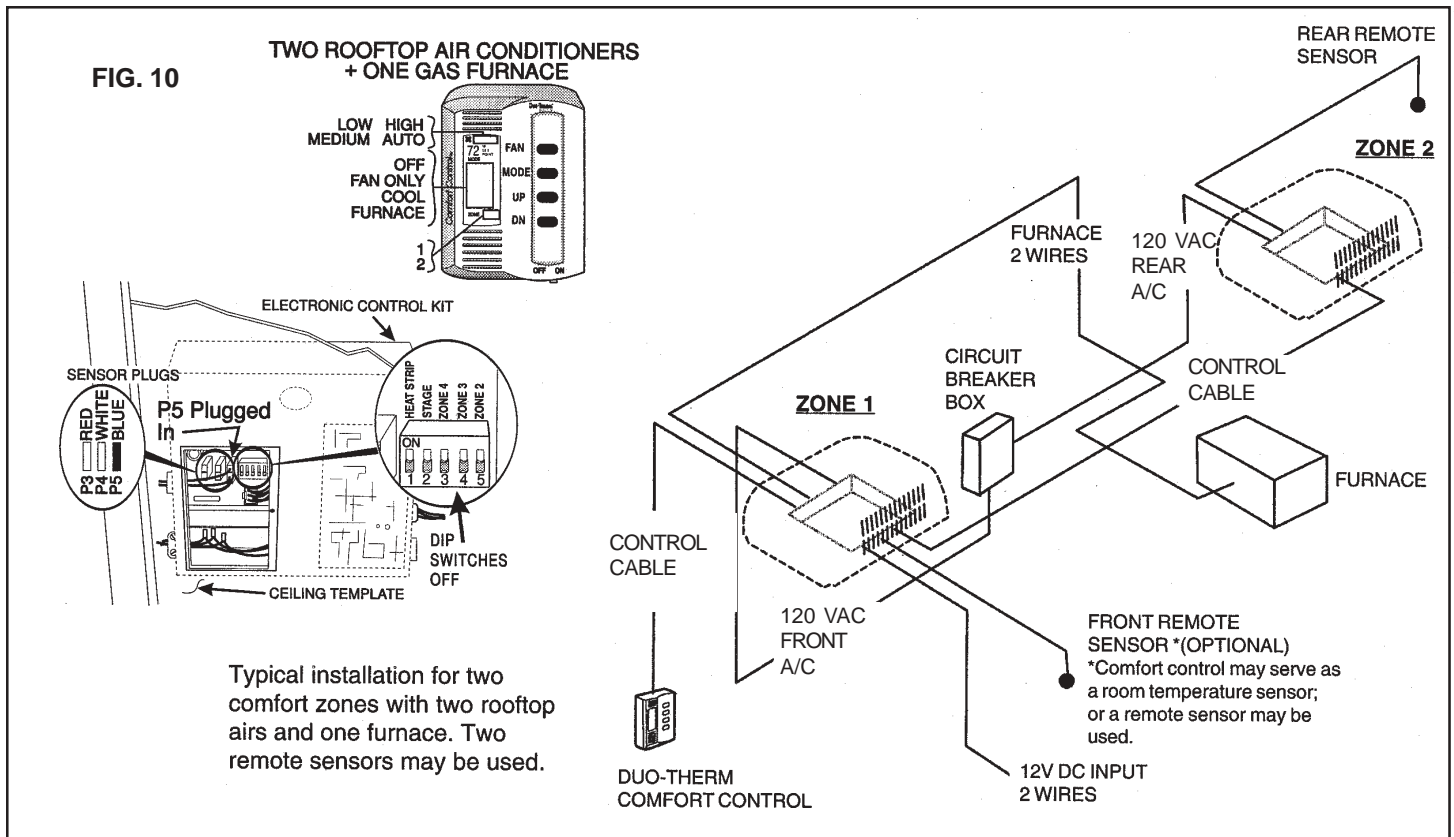

Note: If the configuration of the dip switches and other components are not correct, the unit could operate erratically or not at all.

Configuration is done on the AC power module board, usually at the time of installation of the unit. Locate the control box or electric box that contains the AC power module board.

The configuration for zone 1 is all dip switches “OFF”. Roof top units require the cold control to be plugged into the blue P5 connector on the board and the sensor is snapped in place on the evaporator coil. If a remote sensor is used it will be plugged into the white P4 connector. See FIG. 10.

The Comfort Control Center requires DC voltage to be supplied to the red (positive +) and black (negative -) leads out of the control box.

The control box is connected to the Comfort Control Center (wall thermostat) by a telephone type cable. See section B2. If more than one unit is to be operated off the Comfort Control Center, a second telephone type cable is needed. Both telephone cables are plugged into the control box for the first unit. The second cable is routed to the control box for the second unit. The dip switch for zone 2 needs to be turned “ON”. See FIG. 10. Each additional zone (up to four total zones) requires only the dip switch for its zone number to be turned “ON”.

If an electric heat strip is to be operated by the Comfort Control Center, it is plugged into the control box and the heat strip dip switch is turned “ON”. If a second unit is equipped with a heat strip, the dip switch for the heat strip is turned on along with zone 2 dip switch.

If a furnace is operated by the Comfort Control Center, the thermostat wires are attached to the two (2) blue wires from the control box. The DC voltage from the furnace signals the Comfort Control Center that the system has a furnace and it appears on the display.

If the unit is a heat pump, the ambient sensor for the outdoor temperature is plugged into the red P3 connection. If more than one unit is used, the zone dip switch must be turned “ON”.

The two yellow leads on the control box are for use with the load management system. If the wires are connected or shorted to each other through the metal of the mounting or electrical box, the compressor will not operate.

The stage dip switch is used in dual basement heat pumps or air conditioners. It prevents both compressors from starting at the same time. The second stage is controlled by a temperature differential that is set in the Comfort Control Center. The differential can be set from 0° - 10°.

15. COMFORT CONTROL CENTER

The Comfort Control Center is the component that makes all the decisions for operation depending on the system and the accessories connected to it.

Note: The PAL tester with the air conditioner Comfort Control Center Data Capture Module attached will test the Comfort Control Center and AC power module board.

The location of the Comfort Control Center is very important if it is being used without a remote sensor. Use the following guidelines for the location:

- Locate the remote sensor 54" above the floor.
- Install the remote sensor on a partition, never on an outside wall.
- Avoid locations that are close to doors that lead outside, windows or outside adjoining walls.
- Keep away from discharge from supply registers.
- Place in areas that have good air movement. Avoid corners and under cupboards.

If the remote sensor is used for all zones, the Comfort Control Center can be located anywhere that is convenient.

To check the Comfort Control Center, make sure the **ON/OFF** switch is in the **"ON"** position. Check for DC voltage (10-16 VDC) to the CCC and that the polarity is correct. If the previously mentioned items are correct then do a reset on the CCC.

The reset procedure is as follows:

- Turn the **ON/OFF** switch to **"ON"**. The display light with data should come **"ON"**. If the light and data are not there, see Section B2 Cable Assembly.
- Depress mode to activate display light.
- Depress the bottom two buttons (up & down) together.
- While still holding the two buttons add the third from the bottom (mode), hold all three for a few seconds.
- Release the third (mode) button.
- Release the bottom two (up & down) together.
- Depress the mode button. The display light should be **"OFF"**. If not, repeat steps 2 through 6.

The control should return to the default setting of 68°F for heating mode and 72°F for cooling mode.

16. DC VOLTAGE

A DC volt supply is required for operation of the Comfort Control Center. The operating range is 10 to 16 volts DC. If DC voltages are outside of the operating range, erratic operation may result.

Use a DC voltmeter to check for the incoming DC voltage between the red positive (+) and the black negative (-) at the connections of the electronic control box. If DC voltage is not found check the supply breaker or fuses.

Check the output voltage by using the telephone wall jack. One end of the cable is plugged into the A/C power module RJ-11-6C4P jack. The Comfort Control Center end is plugged into the telephone wall jack. Use a DC voltmeter to test for DC power between the red and black terminals. See FIG. 11 and 12. If voltage is not present, check the control cable. See Section B2.

