

ELECTRICAL SYSTEM TROUBLESHOOTING for MECHANICAL, ELECTRONIC AND BIMETAL CONTROLS

INTRODUCTION

Air conditioners and heat pumps are available with mechanical, electronic and bimetal controls. Refer to the appropriate section for the type of controls that are on the unit to be diagnosed.

A majority of air conditioner and heat pump problems are electrical and can be found very easily.

To find a problem in the electrical system, you need to be able to diagnose the following:

- | | |
|---------------------------|----------------------------|
| 1. Power Source | 9. Motor |
| 2. On/Off Selector Switch | 10. Start Relay |
| 3. Thermostat | 11. Compressor |
| 4. Capacitors | 12. Wiring |
| 5. Main Board | 13. Heat Strip |
| 6. Control Board | 14. Reversing Valve |
| 7. Relays | 15. Change-over Thermostat |
| 8. Relay Boards | |

TOOLS REQUIRED

The air conditioner can be checked with a Voltmeter, Ohmmeter, Clamp-on Ammeters and two good Thermometers. Some Clamp-on Ammeters can read voltage and Ohms.

FIG. 1

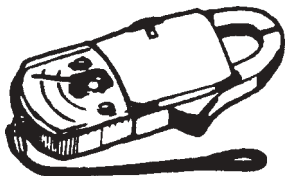

A. QUICK-CHECK TROUBLE- SHOOTING FOR MECHANICAL CONTROLS

For detailed troubleshooting, refer to section noted.

- 1. Air Conditioner/Heat Pump turned on - NO operation**
 - a. Power source problem (Sec. B1)
 - b. Selector switch (Sec. B2)
 - c. Wiring (Sec. B8)
- 2. Air Conditioner/Heat Pump turned on – Fan runs, No compressor operation**
 - a. Power source – low AC voltage (120V AC ± 10%) (Sec. B1)
 - b. Selector switch (Sec. B2)
 - c. Thermostat (Sec. B3)
 - d. Start relay (Sec. B6)
 - e. Start capacitor (Sec. B4)
 - f. Run capacitor (Sec. B4)
 - g. Compressor (Sec. B7)
 - h. Wiring (Sec. B8)
- 3. Air Conditioner/Heat Pump turned on – Compressor runs, No fan operation**
 - a. Power source problem (Sec. B1)
 - b. Selector switch (Sec. B2)
 - c. Fan capacitor (Sec. B4)
 - d. Motor (Sec. B5)
 - e. Wiring (Sec. B8)
- 4. Air conditioner turned on – Fan runs, No heat strip**
 - a. Power source problem (Sec. B1)
 - b. Selector switch (Sec. B2)
 - c. Thermostat (Sec. B3)
 - d. Heat strip (Sec. B9)
 - e. Wiring (Sec. B8)
- 5. Heat Pump turned on – Fan runs, No heat pump operation**
 - a. Power source problem (Sec. B1)
 - b. Selector switch (Sec. B2)
 - c. Thermostat (Sec. B3)
 - d. Reversing valve (Sec. B10)
 - e. Change-over thermostat (Sec. B11)
 - f. Wiring (Sec. B8)

REVISION:

Form No. 3108312.012 10/04
(Replaces 3108312.004)
(French 3109073.019)
©2004 Dometic Corporation
LaGrange, IN 46761

B. DETAILED TROUBLESHOOTING FOR MECHANICAL CONTROLS

We will now start electrically troubleshooting an air conditioner. The best place to begin is at the power source.

1. POWER SOURCE

- a. If the air conditioner compressor or fan fails to operate, chances are it is not receiving power. Be sure the power cord is plugged in and no fuses or breakers are tripped.

Note: Many customers use extremely long power cords that are undersized. If possible, ask the owner to hookup the RV just like it was when the problem occurred. Make note of the wire size and length of wire. Compare it to the chart for wire sizing. See FIG. 2.

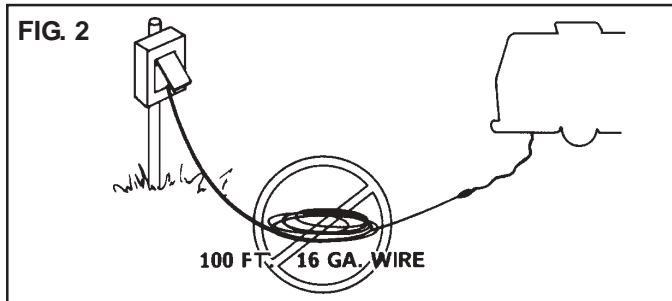

CURRENT IN AMPS	WIRE SIZE					
	16	14	12	10	8	6
	LENGTH IN FEET					
5	47	76	121	192	216	486
10		38	60	96	153	243
15		25	40	64	102	162
20			30	48	76	121

CAUTION

For proper operation of the air conditioner, AC voltage must stay between 108 VAC to 132 VAC. Operation of the unit outside of this voltage range can result in component damage.

- b. To determine if power is reaching the air conditioner, the inside plastic air diffuser box must be removed. The junction box will now be exposed. Remove the cover from the junction box to gain access to the connection between the RV and the air conditioner wires (FIG. 3). Check with a voltmeter for voltage at the twist connections of the air conditioner to RV wires. **USE CAUTION as 120 volts may be present.**
- c. If no voltage is present, the problem is in the coach wiring or breaker/fuse box. If voltage is present at the junction box, proceed to check-out the selector switch on the air conditioner.

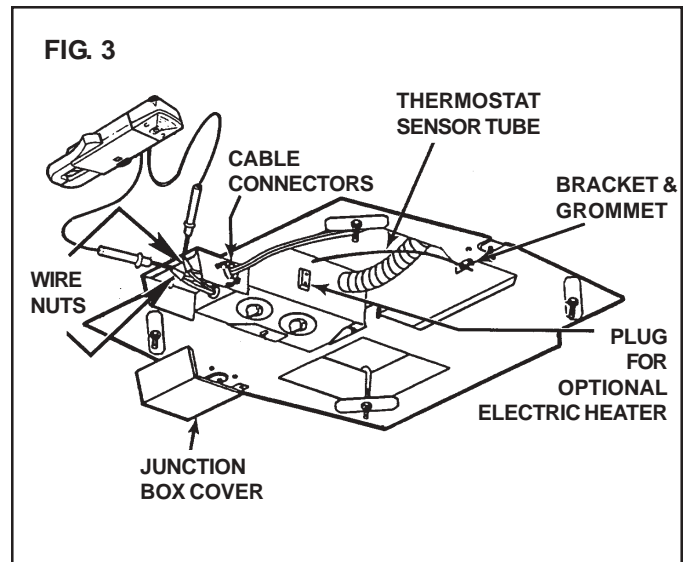

2. ON/OFF SELECTOR SWITCH

The switch can be checked by using a voltmeter with power turned on or by using an Ohmmeter **with power turned off**. For safety reasons we suggest you use the Ohmmeter and proceed as follows:

- a. The air box should still be off. The electrical box needs to be dropped from the template and switch cover removed. Disconnect the wiring from the switch, (be sure to note wire location for proper replacement), and remove it from the electrical box.
- b. There are three different selector switches used in the manufacture of the air conditioner. They are the 10-position, 8-position and 5-position switches. A quick check of the air box decal will indicate which switch is in the air conditioner.
- c. The switch should be checked with an Ohmmeter to determine if continuity exists. The chart shows the correct terminals to check. Example: Switch is in high cool position – the Ohmmeter shows continuity between L1, C and 1. (See FIG. 4)

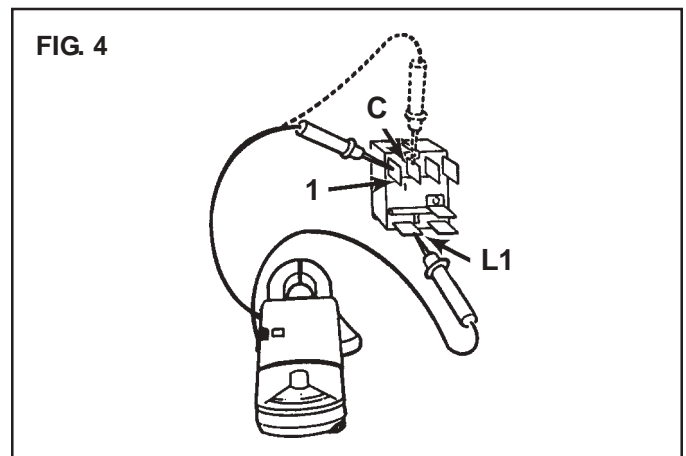

CONTINUITY TEST

SWITCH SETTING	10-Position***	8-Position	5-Position
High Cool	L1, C, 1	L1, C, 1	L1, C, 1
Med. Cool	L1, C, 2	L1, C, 2	L1, C, 2
Low Cool	L1, C, 4	L1, C, 4	L1, C, 4
High Heat	L1, H, 1	NONE*	NONE*
Med. Heat	L1, H, 2	NONE*	NONE*
Low Heat	L1, H, 4	L1, H, 4	L1, H, 4
High Fan	L1, 1	L1, 1	NONE
Med. Fan	L1, 2	L1, 2	NONE
Low Fan	L1, 4	L1, 4	L1, H, 4**

* Note: Selector switch does not have high or medium heat positions.

** Note: Selector switch has no fan settings. If heat strip is not installed, low heat is same as low fan.

*** Note: Also used for Heat Pump

Note: Terminal locations on back of switch will vary with the manufacturer of the switch. Use white numbers stamped on the body of switch for the terminal number

- d. If you do not get continuity through the switch as shown in the above chart, the switch is defective and should be replaced.

3. THERMOSTAT

- a. While you are still in the lower electrical box with the power turned off, the thermostat can be checked with an Ohmmeter.
- b. Two types of thermostats have been used in the manufacture of our air conditioner: cooling only and heat/cool.
- c. The cooling only thermostat is adjusted so the air conditioner will not start the compressor below 65 degrees. In some situations it may be necessary to warm the sensing bulb with your hand or place it in warm water (95 degrees — 100 degrees). (See FIG. 5)

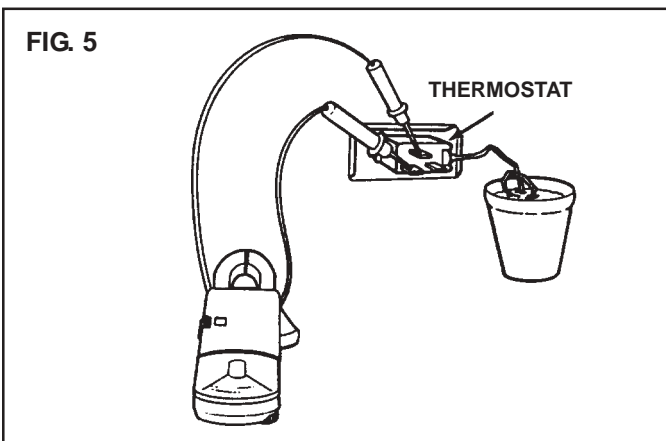

- d. When the contact points make connection, continuity should show across the terminals. Failure to show continuity indicates the thermostat is defective.
- e. The thermostat will not cycle off if the temperature is above 90 degrees. Immersing the sensing bulb in ice water should cause the points to open. Failure to open or break continuity indicates it is defective and should be replaced.
- f. The heat/cool thermostat is very similar to the cooling only thermostat except it contains two sets of contacts. When the cooling contacts make connection, the heating contacts break connection. For example, in 90 degree temperature the cooling contacts will be closed (terminals 1 and 2) and the heating contacts open (terminals 2 and 3). Below 65 degrees, the heating contacts (terminals 2 and 3) will be closed and cooling contacts (terminals 1 and 2) will be open. Failure to properly make and break the circuit indicates a defective thermostat.

CAUTION

Do not apply flame to thermostat sensing bulb. Damage to the thermostat can result.

4. CAPACITORS

- a. The run and blower capacitors are housed in a steel or aluminum case. The run capacitor is the largest. The start capacitor is in a bake-alite shell with a 15000 Ohm bleed resistor across the terminals.
- b. The checking of a capacitor is done with an analog or dial type Ohmmeter. The power must be unplugged from the RV and all switches set to "OFF" position.
- c. Capacitors can hold a charge and they should be discharged by shorting across the terminals with a 15,000 Ohm, 2 watt resistor or using a voltmeter set on the highest AC scale.

⚠ WARNING

Capacitors store an electrical charge. Electrical shock can result if not discharged. Do not short a screwdriver or similar device across device across terminals of capacitor. Damage to capacitor can result.

FIG. 6

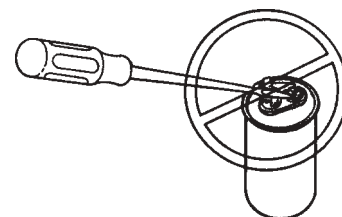

- d. After the capacitor has been discharged remove wire from the terminals and inspect the casing. If it is bulged, cracked or split, the capacitor is defective and should be replaced.

Note: Some capacitors are dented or crushed on the sides by the manufacturer. This is not a defect.

- e. Set the Ohmmeter to mid-range and check for resistance to the case. Be sure the case is clean and paint is scraped away so good contact is made. Any resistance from either terminal to the case indicates a short and the capacitor is defective.
- f. To determine if a capacitor is good, use an Ohmmeter set at the highest scale and check resistance across the terminals. The meter dial should move toward zero then slowly back toward infinity. Reverse the lead and repeat the test. If very little meter movement is noticed, go to next lower scale and repeat test.
- g. On capacitors with a 15,000 Ohm bleed resistor across terminals, the RX1000 scale works best. The hand will dip slightly below 15,000 Ohms and return to 15,000 Ohms. Reversing the lead will show the same results. If a capacitor does not act this way, it is defective and should be replaced.

5. MOTOR

- a. To determine if the windings are good in a blower motor, an Ohmmeter is used. Be sure to disconnect the power supply and be sure all switches are in the “OFF” position to make the test. Disconnect all motor leads, noting their connections so they can be replaced correctly.
- b. The Ohmmeter should show continuity from the white lead to all other leads. Infinity or no continuity indicates an open winding. The motor is defective and needs to be replaced.
- c. Check for continuity to the frame of the motor to each lead. Be sure to scrape paint off motor frame to ensure good contact. If a continuity reading is

observed to any lead, the motor is shorted and needs to be replaced. (See FIG. 8A)

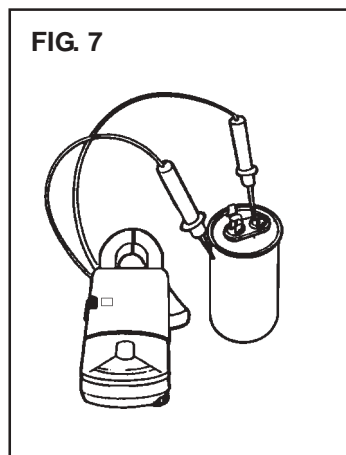

FIG. 7

6. START RELAY (Potential Relay)/PTCR DEVICE

- a. The start relay or potential relay has a coil with very high resistance. The energizing current will only show through the coil when it exceeds line voltage. The increased voltage is generated by the rotor turning in the winding of the compressor.
- b. The relay contact points are normally closed in a de-energized circuit. When power is applied to the compressor, the relay contacts allow current flow to the start capacitor and the compressor starts to turn. When the compressor nears operating speed, a counter-voltage is generated. When the counter-voltage exceeds line voltage, the start relay coil will energize and contact points open. The start capacitor is then removed from the circuit.
- c. To check the start relay, put an ammeter around one of the start capacitor leads. When the power is applied to the compressor, an amperage should show on the meter for approximately one second or less. (See FIG. 8B)
- d. If the meter did not show any amperage reading when power was applied to the compressor, it means the start relay has open contact points or the start capacitor is bad. (See Sec. 4. CAPACITORS)
- e. When there are bad contacts or a bad start capacitor, the compressor may not run. It may “hum” for 15 seconds and trip-out on overload.
- f. When the ammeter shows a continuous current flow, the contact points are stuck closed or the relay coil is open. The compressor will start and run during this condition; however, it will never reach full RPM's and “hum” loudly. The overload will shut it down in approximately 30 seconds from excessive amp draw. This condition can also cause start capacitor failure.

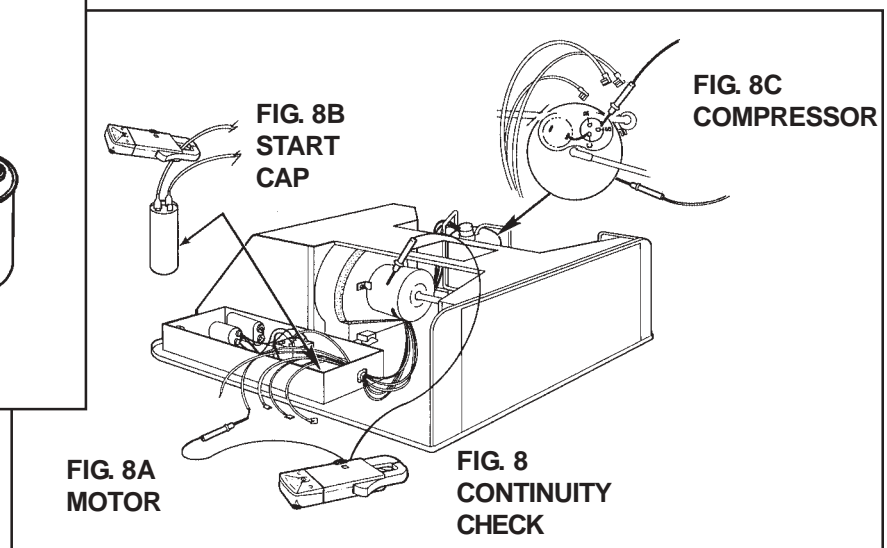

FIG. 8A
MOTOR

FIG. 8B
START
CAP

FIG. 8C
COMPRESSOR

FIG. 8
CONTINUITY
CHECK

- g. It is a good idea to replace the start capacitor whenever you find a relay with stuck contact points. When you replace a start relay, the replacement should be an exact duplicate of the original or compressor damage may result.
- h. The positive temperature coefficient resistor, or PTCR has replaced the compressor start relay and the start capacitor, on some models. It should be checked in two different ways: First, check continuity. Turn the air conditioner circuit breaker to OFF. Disconnect the PTCR from the circuit. Check for continuity. If there is no continuity, replace PTCR.

⚠ WARNING

This is an energized circuit. Shock can occur if not tested properly. Testing to be done by a qualified service technician.

- i. The second check to take is an amperage reading. Clamp an ammeter around the wire from the PTCR to the capacitor. Turn the air conditioner circuit breaker to ON and start the air conditioner. When the compressor starts, there will be an amperage reading for approximately one second or less. If there is no reading, or if there is a prolonged reading, the PTCR or start relay is faulty and must be replaced.

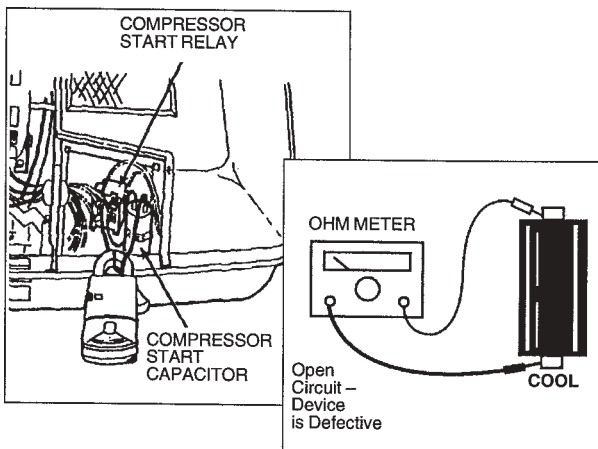

7. COMPRESSOR

- a. The compressor motor can be electrically checked much the same as the blower motor. To do this, be sure to disconnect all power and turn all switches to the "OFF" position.
- b. Remove the terminal cover from the compressor and the three leads connected to the terminals. Be sure to identify the positions so the wires can be replaced correctly.
- c. With an Ohmmeter, check for continuity through the overload device. If there is not continuity and the compressor is hot, allow 15–20 minutes for it to cool. If a repeat of the test show overload to be open, it is defective and requires replacement.

- d. The terminals of the compressor should show continuity between all three terminals. If there is no continuity between any one of the terminals and another, the compressor windings are open and it is defective.
- e. The terminals should be checked for continuity to casing. Be sure paint is scraped away to expose bare metal. If a reading to any one of the terminals is noticed, the compressor is shorted and should be replaced. (See FIG. 8C, Page 4).

⚠ WARNING

Replacement of a compressor requires special equipment and should only be attempted by a service technician with knowledge of repairs to a sealed system. Improper service techniques can result in failure of the replacement compressor.

8. WIRING

- a. Mis-wiring or **loose wires** can cause electrical shorts and/or component failure. Use the unit wiring diagram as a road map to verify the unit is properly wired. Loose spade terminals should be tightened or replaced.

9. HEAT STRIP

- a. Check the heat strip for continuity at the heat strip plug across the outside terminals. An open circuit indicates the fuse link and/or limit may be defective. With the Ohmmeter, check continuity through the fuse link and/or limit. If fuse link and/or limit is open, it is defective and should be replaced.

10. REVERSING VALVE

- a. The reversing valve is the heart of a heat pump. It directs refrigerant flow to the coils to achieve proper direction of flow that allows the same system to supply heated or cooled air to enter the inside atmosphere of the structure according to occupant's desires.
- b. One way to check the reversing valve is to feel the refrigerant line at the top of the inside coil. In the "COOL" mode, this line will be cool or cold to the touch. In the Heat mode, this line will be warm or hot to the touch. If you do not achieve these results, direction of refrigerant flow is not correct.
- c. The Ohms resistance of the reversing valve solenoid coil is approximately 465 Ohms plus or minus (±) 10%. If Ohms reading is within this range, the solenoid coil is good. If Ohms reading is outside this range, replace the solenoid coil.

- d. The reversing valve's solenoid is energized in the "COOL" mode of operation. Verify AC volts are to the solenoid coil when in "COOL" mode. If AC volts are NOT present, verify wiring is correct and the 6-pin terminal connector is proper; and connection is completed through it. If AC volts are present and solenoid coil is good, but the refrigerant flow is not proper, the reversing valve assembly needs to be replaced.

11. Change-over THERMOSTAT

- a. The Change-over thermostat is a capillary tube/bellows-type switch. Its function is to allow the compressor to operate only when outside ambient is 40° F or warmer.

Note: A defective Change-over thermostat can keep the compressor from operating in the COOL or HEAT PUMP modes.

- b. To check the Change-over thermostat, first verify the air temperature at the capillary tube. If the temperatures are above 45° F, continuity should be between terminals 2 to 3 and no continuity between terminals 2 to 1. For temperatures below 40° F, continuity should be between terminals 2 to 1 and no continuity between terminals 2 to 3.

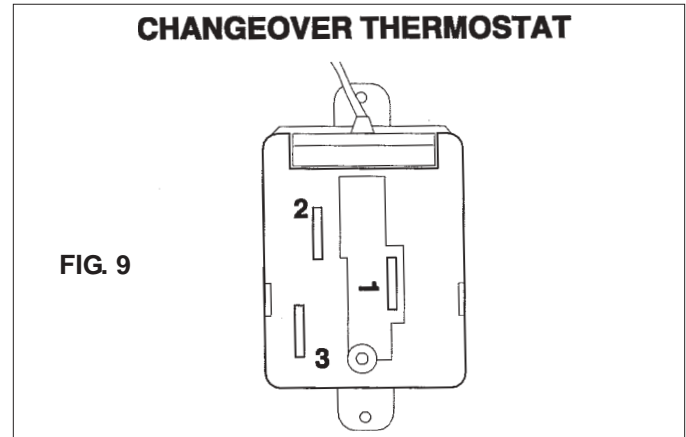

C. QUICK-CHECK TROUBLESHOOTING FOR ELECTRONIC CONTROLS

For detailed troubleshooting, refer to Section noted.

1. **Air conditioner turned on – No operation**
 - a. Power source problem (Sec. B1)
 - b. Wiring (Sec. B8)
 - c. Main Board (Sec. D2)
 - d. Control Board (Sec. D3)
2. **Air conditioner turned on – Fan runs, No compressor operation**
 - a. Wiring (Sec. B8)
 - b. Compressor (Sec. B7)
 - c. Cold Control (Sec. D4)
 - d. Main Board (Sec. D2)
 - e. Control Board (Sec. D3)
3. **Air conditioner turned on – Compressor runs, No fan operation**
 - a. Wiring (Sec. B8)
 - b. Run capacitor (Sec. B4)
 - c. Motor (Sec. B5)
 - d. Main Board (Sec. D2)
 - e. Control Board (Sec. D3)

- b. To check all other components except the main board and the control board:
 - Disconnect all power to the air conditioner. Remove the incoming AC black wire, the compressor wire from the compressor relay on the main board and the high fan wire from the main board. Then connect the three wires together; connect the AC power to the air conditioner. The compressor and the motor should operate.
 - If all other components check-out correctly, the module board or control board should be replaced. Of these two, the main board will usually be the primary problem; replace parts as necessary.

Note: There is more than one type of main board and control. Defective boards and controls must be replaced with identical parts. Operational failure or damage may occur if a substitute is used.

2. MAIN BOARD

On electronic units, two types of main boards have been used. They are 120 AC volt and DC volt controlled.

D. DETAILED TROUBLESHOOTING FOR ELECTRONIC CONTROLS

1. GENERAL

- a. On electronically controlled units, the switch and thermostat have been replaced with the main board and control board. A visual check of the ribbon cables, connectors, and board components should be made for loose, damaged or burned components.

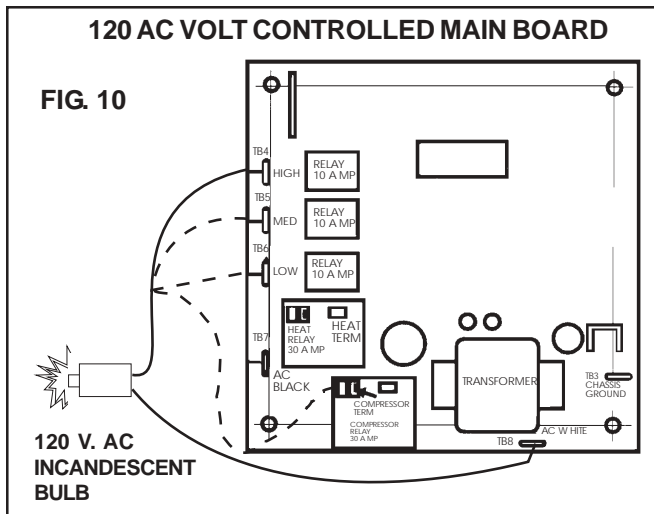

a. 120 AC VOLT CONTROLLED:

- Disconnect all power to the air conditioner. Remove the fan speed wires and the compressor wire from the main board. Set the control board to “COOL” and “HIGH FAN” positions. Connect power to the air conditioner. Verify the lights on the control board are on. If no lights are on, remove control board and attach directly into main board ribbon cable. If lights do not come on, replace the main board.
- With lights on control board, use a 120 VAC incandescent bulb with one lead on the AC WHITE terminal and the other lead on HIGH, and then to compressor terminal to verify the circuit is being completed through the main board. Switch the control pad to other settings and verify all circuits are being completed. If not, replace the main board.

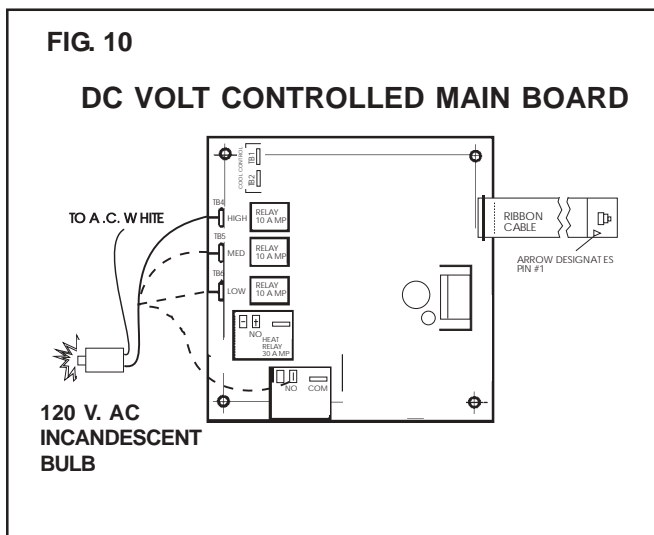

b. DC VOLT CONTROLLED:

- This main board is controlled by DC volts supplied from the control board.
- To check DC volts, be sure “OFF/ON” switch on control board is “ON”. Measure the outside (#1 and #10) terminals on the cable between the main board and the control board. The operating range is 10 to 16 volts DC. If DC volts is not within this range, correct the DC volt supply.
- To check the circuit completing capabilities of this board, follow the same procedure as in the previous section, 120 AC VOLT BOARD.

3. CONTROL BOARD

On electronic units two types of control boards have been used. They are 120 AC volt and DC volt controlled.

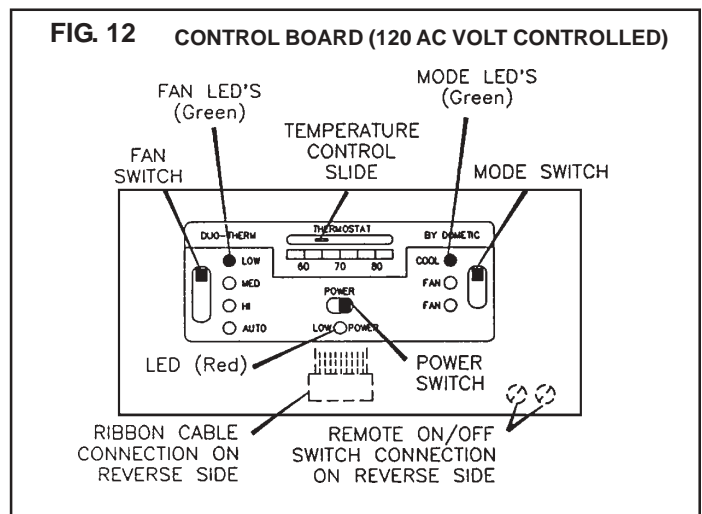

a. 120 AC VOLT CONTROLLED

- This control board is a signal receiver and completer. All power is supplied by the 120 AC volt main board. With the power switch “ON”, the FAN and MODE LED’s will illuminate.
- Move the fan switch to all positions – the LED for each position should light. Next, move MODE switch to all positions – the LED for each position should light. If all the LED’s light when switches are changed, the control board is good.
- If a LED does not light when switch is at that position, check the cable connections for a bent pin or improper connection. Also check for any discolored or burnt areas on the board. If a discolored or burnt area is found, correct the short in the cable before installing a new control board.
- If all lights light, and no discoloration or burnt area is found, the control board does **NOT** need to be replaced.

FIG. 13 CONTROL BOARD (DC VOLT CONTROLLED)

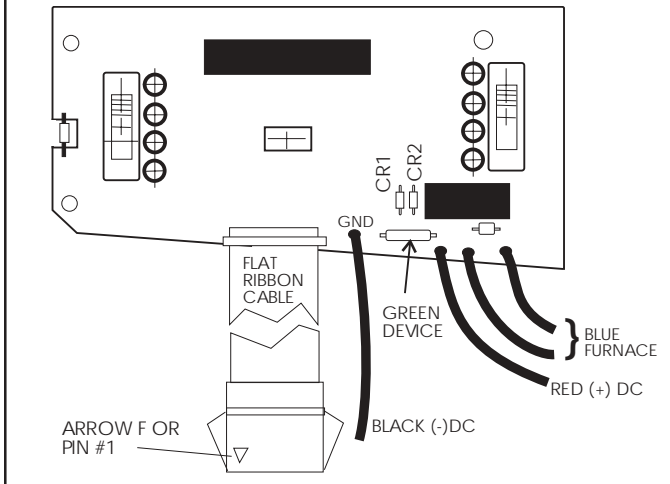

b. DC VOLT CONTROLLED

- This control board is wired to a DC volt supply and is capable of operating a DC volt furnace as well as operating the air conditioner. Only one of these will operate at a time. When the mode selection switch is at “**GAS HEAT**”, all lights for the air conditioner will not illuminate and gas heat will illuminate.
- DC volts is wired to the control pad attaching positive (+) DC to the red Wire and negative (-) to the black wire. POLARITY has to be correct for operation.
- The control board sends DC volts to the main board and the main board sends signals to control board. It then completes the signals according to fan selection and mode selection to the appropriate appliance (air conditioner or furnace)
- The DC volt operation range is 10 to 16 volts. To verify DC volts, check between the black wire and the red wire. If no volts are detected or voltage is outside of the operation range, correct the DC volt supply. If voltage is within the operating range, next check between pin 1 and 10 on the cable.
- The voltage should be the same. If none is detected the control pad is defective. Before replacing the part, verify where the wire is shorted and correct the problem. The most likely problem area would be in the cable that connects the main board and control board.

- To check the gas heat mode, verify the control board is turned on, temperature control slide is all the way to the right, mode switch is to gas heat position and green LED is on. Next, remove furnace wiring from the two blue wires. Then check for continuity on the blue wires. Continuity means the thermostat is good.
- If your results are no continuity, then check for DC volts between black wire and bottom of **CR2 Anode** (side closest to green device). See FIG. 12. If DC volts are not present, check cable and main board. If DC volts are present (10 to 16), place a jumper wire between black wire and bottom of CR2 Anode. Next check continuity on the blue wires. Lack of continuity designates a defective control board. A continuity reading indicates a problem with the cable or main board.
- If the furnace continues to operate when the control board is turned “**OFF**”, check continuity on blue wires. Lack of continuity designates the control board is good. Continuity on the blue wires designates a defective control board.

! WARNING

Be sure the following check is done properly. An incorrect test will damage the control board.

4. COLD CONTROL

(Low Temperature Protection Device)

- On the roof mounted ducted (in ceiling duct) air conditioners, the cold control is used to prevent the evaporator coil from forming ice on the coil. Restricted air entering or exiting the air conditioner is the most common cause.
- There are two types of cold controls: normally closed and normally open.
- If the cold control is wired in the power supply to the compressor, it is a “normally closed” type (continuity).
- It will open the circuit at a temperature below freezing and will close when the temperature of the line reaches approximately 65 to 70 degrees F.
- Do a continuity test through the control. Continuity means the control is completing the circuit; no continuity means the control is not completing the circuit. Verify the temperature of the line before changing.

- f. If the cold control is wired other than in the power supply to the compressor, it is a normally open type (no continuity). When the refrigerant line it is attached to reaches below freezing temperatures, it will close (continuity) and will open (no continuity) when the temperature of the line reaches approximately 65 to 70 degrees F. Verify temperature of the refrigerant line before changing.

E. QUICK-STEP TROUBLESHOOTING FOR BIMETAL RELAY CONTROLS

For detailed troubleshooting, refer to section noted.

1. **Air Conditioner turned on – No operation**
 - a. Power source problem (Sec. B1)
 - b. Thermostat (Sec. F1)
 - c. Relay Board (Sec. F2)
 - d. Wiring (Sec. B8)
2. **Air Conditioner turned on – Fan runs, No compressor operation**
 - a. Power source problem (Sec. B1)
 - b. Thermostat (Sec. F1)
 - c. Relay Board (Sec. F2)
 - d. Start Relay (Sec. B6)
 - e. Start Capacitor (Sec. B4)
 - f. Run Capacitor (Sec. B4)
 - g. Cold Control (Sec. D4)
 - h. Compressor (Sec. B7)
 - i. Wiring (Sec. B8)
3. **Air conditioner turned on – Compressor runs, No fan operation**
 - a. Power source problem (Sec. B1)
 - b. Thermostat (Sec. F1)
 - c. Relay Board (Sec. F2)
 - d. Fan capacitor (Sec. B4)
 - e. Motor (Sec. B5)
 - f. Wiring (Sec. B8)

- Connect the “**YELLOW**” wire from the air conditioner to the “**Y**” terminal on the thermostat.
- Connect the “**BLUE**” wire from the air conditioner to the “**H**” terminal on the thermostat.
- Connect the “**ORANGE**” wire from the air conditioner to the “**G**” terminal on the thermostat.
- Push the thermostat wires into hole in wall and fill excess hole with insulation.
- Mount thermostat base to the wall with screws provided.
- Check all thermostat wires on base to ensure they are completely clear of the bimetal coil of the thermostat. Adjust if necessary.
- Replace thermostat cover.

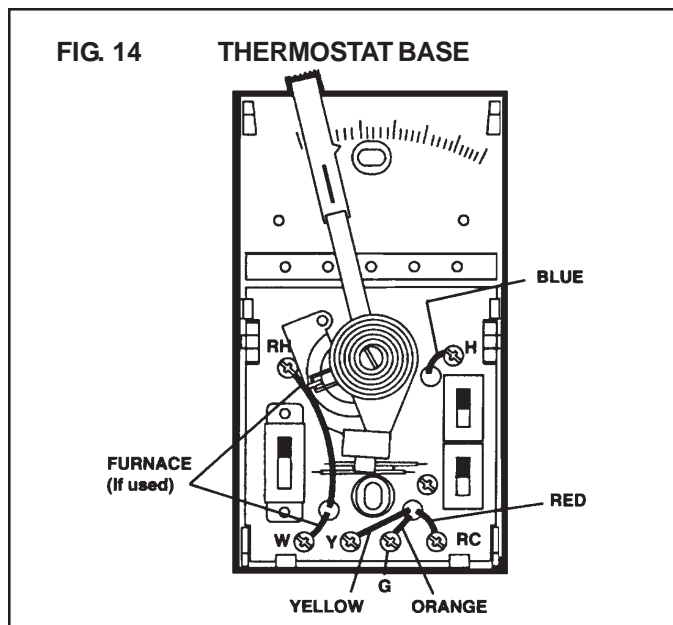

F. DETAILED TROUBLESHOOTING FOR BIMETAL RELAY CONTROLS

1. **THERMOSTAT (Bimetal Type)**
 - a. The thermostat is mounted on a wall of the RV and is connected to the relay board (mounted in the return air grille assembly) with red, orange, yellow and blue wires.
 - b. The thermostat is a “heat/cool thermostat”. These instructions cover only the cooling connections required. If connection of furnace is required, follow the instructions provided with the furnace. Normally the furnace will connect to the “RH” and “W” terminals on the thermostat.
 - Remove the cover of the thermostat.
 - Connect the “**RED**” wire from the air conditioner to the “**RC**” terminal on the thermostat.

- c. If nothing operates on the air conditioner, remove the return air grille assembly and verify the red, orange, yellow and blue wires are properly connected (red-to-red, orange-to-orange, etc.).
- d. Next, disconnect the red wires and check for 12 volt DC between the red wire from roof section and the orange or blue wire from roof section. If no voltage received, refer to Section F2. If voltage is received, the problem lies with the thermostat or thermostat wires.
- e. Next, disconnect all 4 wires (red, orange, yellow and blue) from the thermostat. With the thermostat set on **COOL** mode, **FAN** mode set on **AUTO** and **HIGH**, and temperature selector set lower than the room temperature. Check for continuity between terminal RC (red wire) and terminal G (orange wire); and RC (red wire) and terminal H (blue wire). If continuity is achieved on each, proceed with the next step.

- f. Set fan switch to **LOW**. Continuity should **NOT** be present between terminal RC and Terminal H, but present between the other terminals (Y & G) and terminal RC.
- g. If all of the previous checks are good, the thermostat is good, do not replace it. If any one of the previous checks are not correct, replace the thermostat.

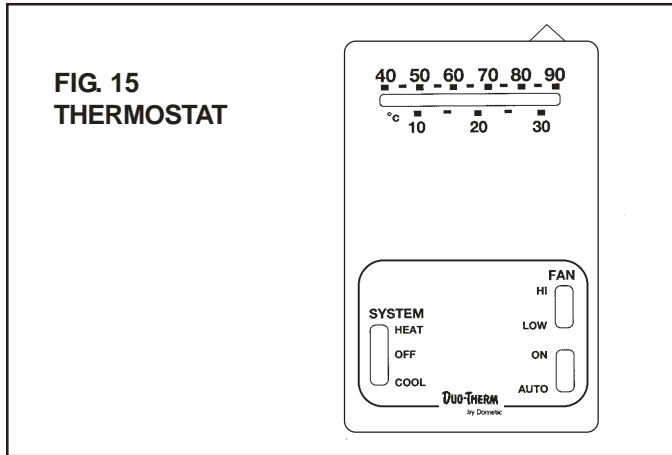

2. RELAY BOARD

- a. The relay board consists of a transformer, compressor relay, two fan relays and other components. If any one of these are defective, the complete relay board must be replaced.
- b. The relay board completes circuits to the fan motor and compressor depending on thermostat and mode settings
- c. The first check would be to turn all power off to the air conditioner and disconnect the four wires (red, yellow, orange and blue) from the thermostat and wire all 4 wires together.
- d. Next, turn on power to the air conditioner. The compressor and high fan should operate. Next, remove the blue wire from the others.
- e. With the red, yellow and orange wires connected, the compressor and low fan should operate. If these checks are not correct, the problem is in the relay board or its wiring. Remove the cover from the relay box housing and verify the red wire is on terminal RC, orange wire is on terminal G, blue wire is on terminal H and yellow wire is on terminal Y.
- f. With AC power to the relay board, check between terminals RC and G or H. There should be 12 volts DC. If no volts are detected, the transformer on the relay board is defective. Replace the relay board.
- g. If 12 volts DC is available, disconnect power to the air conditioner and remove the **HI FAN** wire (black) and the **LOW FAN** wire (red) and the compressor wire (large blue) from the NO terminal on the compressor relay on the relay board.
- h. Next, connect all 4 low voltage wires together (red, yellow, orange and blue) that go to the

thermostat from the relay box. Provide power to the air conditioner. Using an incandescent bulb, check from AC white terminal (one lead from bulb) to **NO** terminal and **HI FAN** terminal (other lead from bulb). The bulb should illuminate.

- i. Next, disconnect the blue wire from the other three. Check from AC white to **LO FAN** and **NO** terminals. The light should illuminate. If these tests are correct, the relay board is good – do not replace it.
- j. If any one of these tests are incorrect, replace the relay board.

