

TO TROUBLESHOOT ERRATIC CHECK LIGHT (GAS) on AMES/AES Refrigerators with 2931842XXX & 2931843XXX Power Modules

INTRODUCTION

The purpose of this Bulletin is to aid the technician in proper diagnosis and repair of AMES/AES refrigerators. This Bulletin will provide the technician with information to find the hidden variable/s that can cause an erratic check light when the refrigerator is operating on gas.

PARTS AND TOOLS REQUIRED:

PAL® Tester
Millivolt Meter
Volt-Ohm Meter
Manometer/Gas Pressure Gauge
Pliers & Screwdrivers
3108702.675 Kit, Wire Harness 7, 11 & 12 Series,
Silhouette S15XX, S16XX, S18XX Series
3108702.683 Kit, Wire Harness RM7030 & RM7130

QUICK-CHECK TROUBLESHOOTING LIST

1. DC Power Supply
2. Gas Supply
3. Components:
 - A. Thermocouple
 - B. Burner
 - C. Reignitor
 - D. Electrode
 - E. Solenoid
 - F. Power Module
 - G. Control Panel
4. Grounds
5. Installation of 3108702.675 or 3108702.683 Wire Harness Kit

DETAILED TROUBLESHOOTING LIST

1. DC POWER SUPPLY

Clean Direct Current (DC) power is mandatory for high-tech circuits to operate as designed. The sources for DC power are a battery and a converter.

A battery will provide straight line DC power, but extended operation will require recharging of the battery by the converter or the alternator.

The converter and alternator produce DC power by a series of diodes that rectify alternating current to DC. A battery or capacitors can be used to clean up the AC ripple that is present after AC voltage has been rectified.

AC ripple can be measured by a digital voltmeter set on the AC scale at the main terminal block connections. Six volts AC or less is acceptable. See FIG. 1.

A brief interruption of the DC power supply while refrigerator is operating on gas can cause a check light; for example: Turning the refrigerator OFF-ON while operating in the gas mode can cause a check light. The switching of relays from converter power to battery power when unplugging from shore power or shutting down of the generator could interrupt DC power long enough to cause a check light.

The thermocouple produces 25–30 MVDC when operating. When DC power is interrupted and restored, the thermocouple may not have sufficient time to cool. If the power module sees above 6 MVDC, when power is restored the power module will assume a problem in the gas mode and immediately turn on the check light.

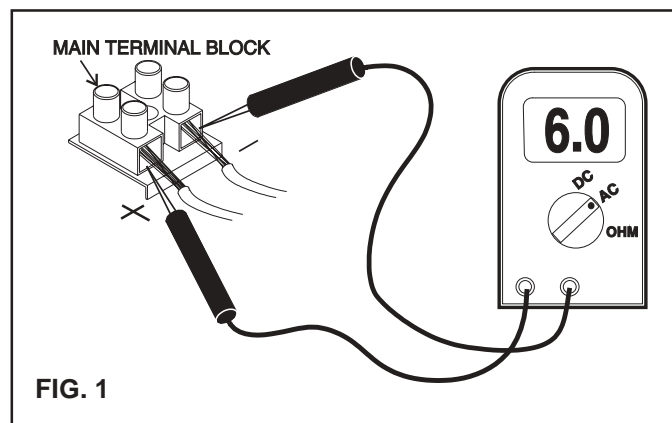

REVISION:

Form No. 3106465.010 10/04
(Replaces 3106465.002)
©2004 Dometic Corporation
LaGrange, IN 46761

2. GASSUPPLY

The refrigerator requires 11 inches water column with half of all the BTU's of the RV turned on (half of all appliances turned on). With all the appliances off, the pressure to the refrigerator should not exceed 12 inches water column. The gas pressure for the refrigerator is taken at the test port after the solenoid with the refrigerator operating. See FIG. 2 & 2A.

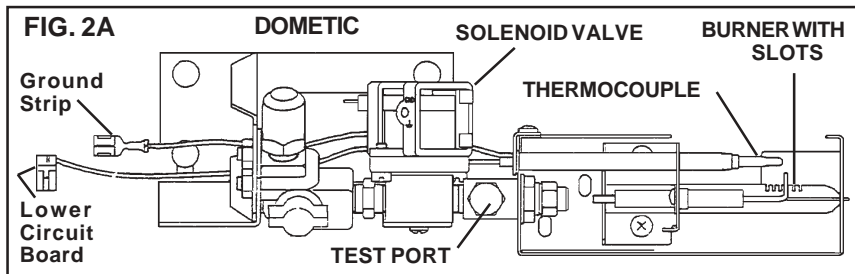
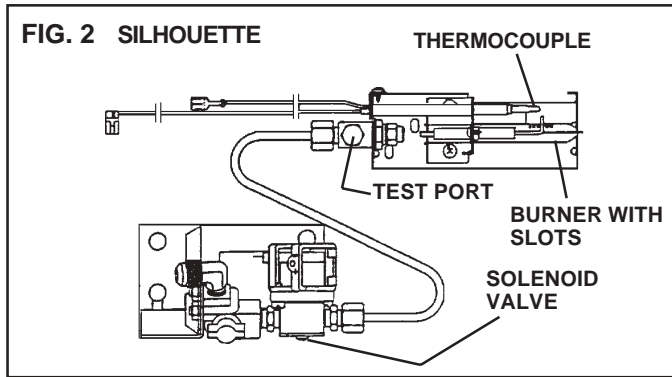

- C. **The Reignitor** is an electronic device that produces high voltage to create a spark to ignite a flame at the burner, when refrigerator operates on LP gas.

Verify proper DC power is at the positive (+) and ground (-) terminals. The reading should be within one volt of the voltage at the main terminal block during the trial-for-ignition. (See Item 4, Grounds, Paragraph E).

The reignitor installed on the refrigerators as original

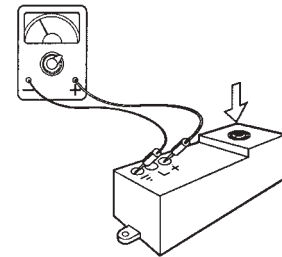

equipment is part number 2931132019 (RV Gas Model 679). This reignitor is rated 50 MA. This reignitor may also be used on any other model.

DO NOT install the Channel Mark 6, Model 12E Reignitor (shown below) as a service replacement part. (FIG. 3 & 3A).

3. COMPONENTS

- A. **The Thermocouple** is a component that extends over three slots on the burner assembly so its tip is in the path of the flame. During normal gas operation, the thermocouple should produce 25 to 30 millivolts when connected to the lower circuit board. Any reading below 18 millivolts could cause erratic gas operation. NOTE: A reading of 18 or less could be caused by low gas pressure or improper thermocouple location. The thermocouple should be centered over the burner and extend over 3 slots. See FIG. 2 & 2A.
- B. **The Burner** is a horizontal slotted metal tube located below the flue tube of the cooling unit. The burner should be cleaned periodically (at least once a year). To clean the burner, remove from the refrigerator and check for any foreign residue (rust, spider webs, etc.) that could cause a deflection of the gas flow or flame. Soak the burner in an alcohol based solvent and allow to air dry. Reinstall in refrigerator and leak check all gas connections with an approved leak check solution. See FIG. 2 & 2A.

FIG. 3



FIG. 3A

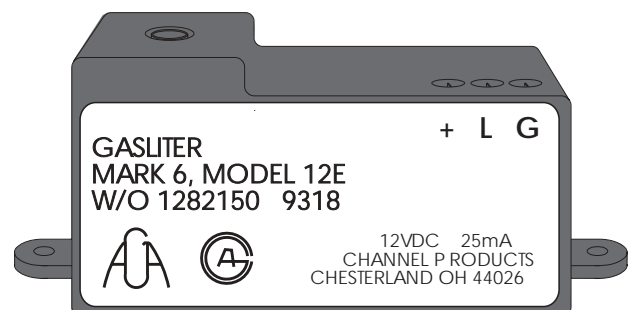

Installing the Channel Mark 6, Model 12E, rated 25 MA can result in failure to ignite on gas if the DC power supply is below 12.5 volts DC. The reignitor will see low voltage and not produce a spark, resulting in flame failure lockout.

Installation of the Channel Products, Inc., Gasliter Mark 6, Model 12E, will **VOID** the Warranty on the refrigerator.

D. Electrode

First, do a visual check for cracks or breaks on the ceramic insulator. Verify the mounting bracket is attached properly to the electrode. If either of the above is found, replace the electrode. The spark gap must be set at three sixteenths (3/16") of an inch and tip of electrode above the slots in the burner as shown below.

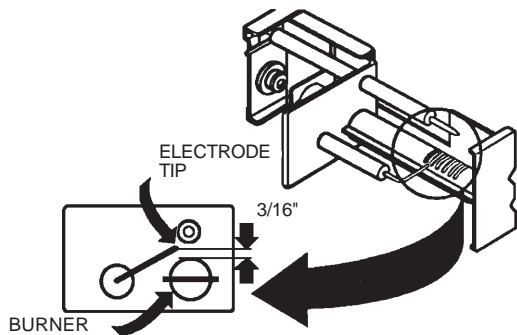

E. The Solenoid Valve receives DC power when the AMES/AES control selects LP gas operation. The solenoid coil opens an internal valve seat and allows gas to follow to the main orifice.

Check the solenoid valve with a properly calibrated ohm meter. Remove one of the connectors from the solenoid and measure the resistance across the terminals. The proper reading would be 44–53 ohms.

Hook a manometer to the test port. With DC power supplied to the solenoid terminals, a gas pressure reading of 11–12 inches of water column should be present. If no pressure or low pressure is present at the test port, the gas solenoid is defective and should be replaced. NOTE: Verify the LP gas system pressure before replacing a valve with low pressure.

F. The Power Module monitors the DC and AC power supplied

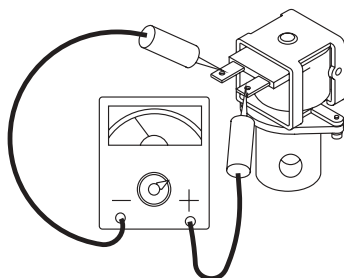

to the refrigerator. It coordinates the operation between DC, AC and gas in conjunction with the setting of the display panel.

Check the fuse(s) under the cover on the power module for continuity. Replace with same size if bad. Inspect for a loose relay and Plug 3 (P3) on the board. If loose, replace board. See FIG. 6.

When the refrigerator requires additional cooling, the power module will send DC voltage to the solenoid and reignitor. The trial-for-ignition will last for 45 seconds and at the end of this period, the check light will come on if there is no flame.

NOTE: When the thermocouple output is between 7–13 millivolts DC, the DC voltage to the reignitor will be turned off. If the flame is extinguished, the power module will not supply DC power to the reignitor until the millivolts DC drop to 7–13 MVDC. It may take 10–15 seconds for the thermocouple to cool.

The PAL® Tester will allow for proper testing of the integrity of the upper and lower circuit cards. The PAL® Tester is available from your Dometic parts distributor. See "G. Control Panel".

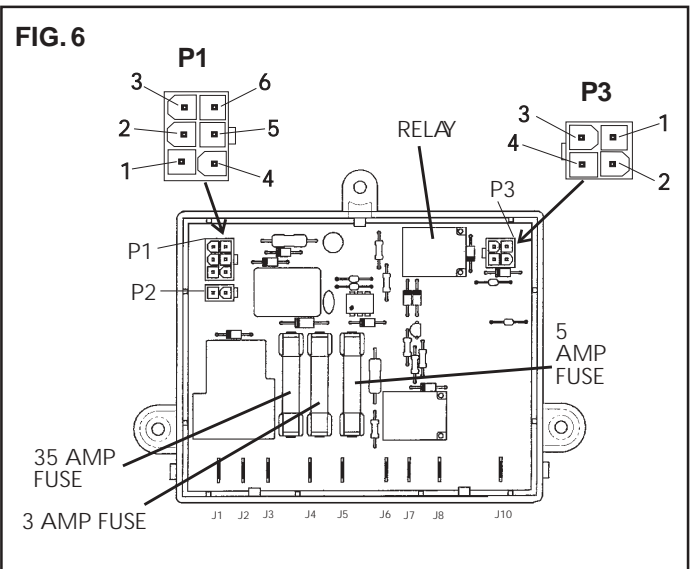

G. Control Panel

- 1) With the main ON/OFF switch on the control panel in the OFF position:
 - Check for DC voltage at Plug 1 (P1) Terminal 4 of lower circuit board. See FIG. 6.
 - If no voltage, check the fuse condition on lower circuit board. Replace if blown. Check for DC between J4 and J10 on the lower circuit board. If fuse is good and there is DC voltage at J4, remove and replace lower circuit board. See FIG. 6.
- 2) With main ON/OFF switch on the control panel in the ON position:

Check for DC voltage at P1 Terminal 4 on the power module. See FIG. 6. It should be within ± 1 volt of the supply DC to the refrigerator.

Next, check for DC voltage at Plug 1 (P1) Terminal 1 of the power module. If no voltage is present, then the switch is faulty and the control panel should be replaced.

If DC voltage is present at P1 Terminal 1, check for DC voltage on P1 Terminal 3 on the power module. If there is **NO** DC power present, the power module is faulty and should be replaced. See FIG. 6.

The PAL® Tester will allow for proper testing of the integrity of the upper and lower circuit cards. The PAL® Tester is available from your Dometic Parts Distributor.

4. GROUNDS

A quick, easy way to test for ground problems can be done with a millivolt meter.

- A. Connect a digital millivolt meter to J3 and J10 of power module. See FIG. 4

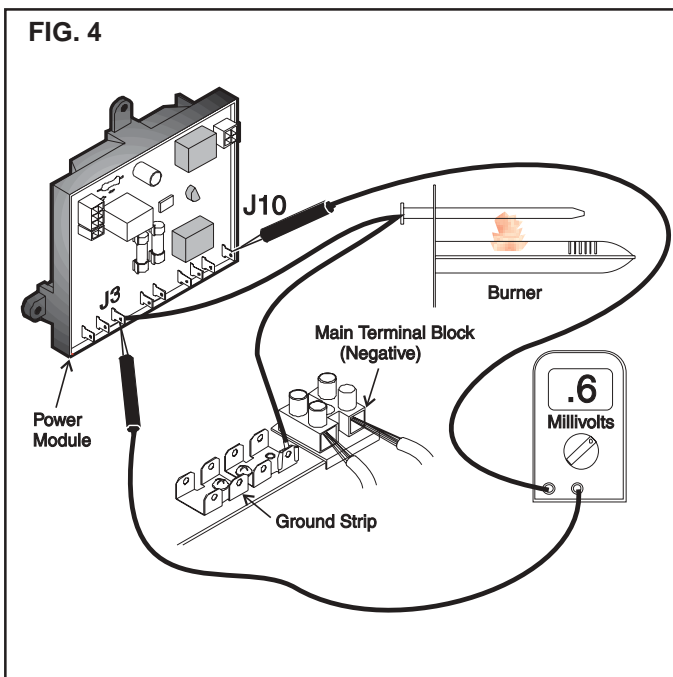

- B. Pull one of the wires off the gas solenoid valve. The millivolt reading should be 1–2 or less.
- C. Put the wire back on the gas solenoid valve and with the reignitor sparking, the digital millivolt meter should read 5 millivolts or less at this time. If the millivolt meter shows more than six (6), a ground problem exists. Proceed to Section 5, Installation of 3108702.675 or 3108702.683 Wire Harness.
- D. The digital millivolt meter should register between 25–30 millivolts with the gas flame burning.
- E. Shut the manual gas cock valve off (see FIG. 5 & 7)

and watch the millivolt reading as it drops. Note the millivolt reading when the reignitor starts sparking (7–13MV). Repeat Step E several times. If reignitor fails to spark or sparks continuously, it is defective.

- F. Check all connections on the 6-terminal ground bus bar for tightness and corrosion. Make sure that the

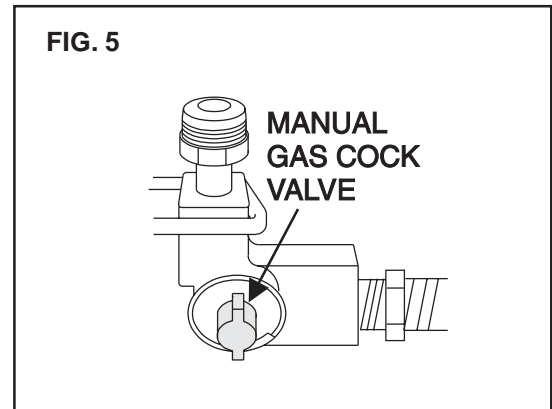

connection to the refrigerator's 4-pole main DC terminal block are clean and tight. The same checks should be made to the coach's connection at the battery and converter.

5. INSTALLATION OF 3108702.675 or 3108702.683 WIRE HARNESS

In the event of repeated check light occurrences, Dometic recommends that the 3108702.675 or 3108702.683 wire harness be installed. The wire harness serves as a precaution to lessen the possibility of intermittent check lights which can be the result of loose or corroded grounds.

- A. Remove the covers from both the power module and the reignitor.
- B. Remove the cable assembly connecting P3 on power module to the gas solenoid and reignitor. It can be discarded. See FIG. 6 and 6A.
- C. Disconnect the white wire from J10 on the power module and the 6-terminal ground bus bar. It also can be discarded. See FIG. 6 & 7.
NOTE: Some models have the green/yellow wire from the ignitor connected in with the terminal on the white wire. It is removed along with the white wire. See FIG. 6, 6A & 7.
- D. Remove the green/yellow wire from the negative terminal (–) on the reignitor and discard. See FIG. 6A & 7.
- E. Disconnect the thermocouple lead from 6-terminal ground bus bar. Reconnect the thermocouple lead to J10 on power module. See FIG. 6. Bend the spade connector to a 45 degree angle so the cover will go back in place. Be sure the spade connector does not contact AC terminal at J8.
- F. Plug the new cable into the P3 plug on power module. See FIG. 6.
- G. Connect the end of the white wire from P3 (two white wires spliced into spade terminal) to the 6-terminal ground bus. See FIG. 7.

- H. Connect the remaining white wire to the gas solenoid valve.
- I. Connect the yellow wire from P3 (two yellow wires spliced into spade terminal) to the remaining terminal on the gas solenoid valve.
- J. Connect the remaining yellow wire with smaller spade terminal to the (+) terminal on the reigniter. See FIG. 6A & 7.
- K. Connect the new black wire to the 6-terminal ground bus and the (-) terminal on the reigniter. See FIG. 6A.
- L. Inspect wiring to make sure it is not shorting to other wires or components. Replace reignitor and power module covers.
- M. Choose the correct wiring diagram from the Chart below and install it over the old wiring diagram. See FIG. 8.

- N. Test operation of the refrigerator per the Installation and Operating Manual.

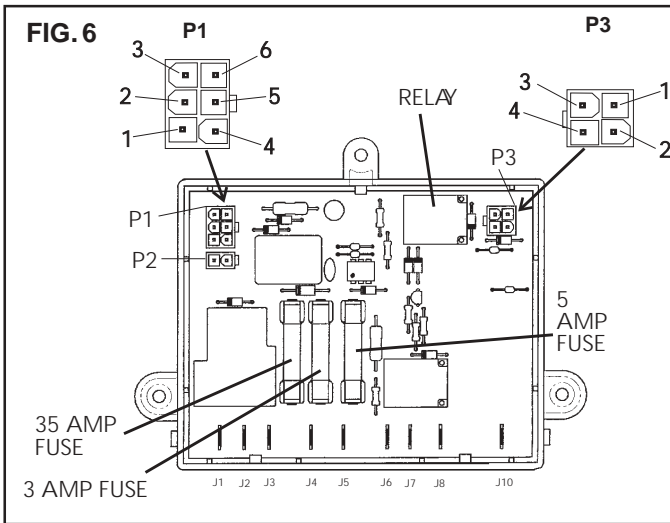

FIG. 8

MODELS	DESCRIPTION	WIRING DIAGRAM NO.
S1621, S1821	Silhouette 6 & 8 cu. ft. AMES 2-Way	2931878
S1631, S1831	Silhouette 6 & 8 cu. ft. AMES 3-Way	2931879
S1521	Silhouette 5 cu. ft. AMES 2-Way	2931895
S1531	Silhouette 5 cu. ft. AMES 3-Way	2931896
RM7030, RM7130	Dometic 10 cu. ft.	2932156
RM2607, RM2807 RM2611, RM2811 RM3607, RM3807	Dometic 6 & 8 cu. ft. AMES/AES 2-Way	2932177
RM2607, RM2807 RM2611, RM2811 RM3607, RM3807	Dometic 6 & 8 cu. ft. AMES/AES 3-Way	2932178
RM2612, RM2812	Dometic 6 & 8 cu. ft. 12 Series	2932188

